



INSTRUCTIONS FOR USE Slit lamp

BM 900[®]

18. Edition / 2021 – 08



HS HAAG-STREIT
DIAGNOSTICS

INSTRUCTIONS FOR USE

Slit lamp

BM 900[®]

18. Edition / 2021 – 08

Preface

Thank you for choosing a Haag-Streit device. Provided you comply carefully with the regulations in these instructions for use, we can guarantee reliable and trouble-free use of our product.



WARNING!

Read the instruction manual carefully before commissioning this product. It contains important information regarding the safety of the user and patient.



NOTE!

For USA only: Federal law restricts this device to sale by or on the order of a physician or licensed practitioner.



WARNING!

This device is equipped with high intensity light emitting diodes. Excessive exposure of patients in treatment with certain medication may lead to phototoxic adverse reactions, due to higher photosensitivity.

Contents

• 1 Safety	4	◦ 8.2 Stereo microscope.....	12
◦ 1.1 Comments on these instructions for use.....	4	◦ 8.3 Instrument base.....	13
◦ 1.2 Ambient conditions.....	4	◦ 8.4 Dimensions.....	13
◦ 1.3 Shipment and unpacking.....	4	• 9 Maintenance	13
◦ 1.4 Installation warnings.....	4	◦ 9.1 Device inspection.....	13
◦ 1.5 Operation, environment.....	5	◦ 9.2 Servicing.....	13
◦ 1.6 Light toxicity.....	5	◦ 9.3 Cleaning and disinfection.....	13
◦ 1.7 Disinfection.....	5	◦ 9.4 Replacing the illumination mirror.....	14
◦ 1.8 Warranty and product liability.....	6	◦ 9.5 Dust cover.....	14
◦ 1.9 Reporting obligation.....	6	• 10 Appendix	14
◦ 1.10 Description of symbols.....	6	◦ 10.1 Accessories / functionals parts / detachable parts / consumables.....	14
• 2 Intended purpose / intended use	6	◦ 10.2 Legal regulations.....	15
◦ 2.1 Device description.....	6	◦ 10.3 Classification.....	15
▪ 2.1.1 Intended users.....	7	◦ 10.4 Disposal.....	15
◦ 2.2 Medical purpose.....	7	◦ 10.5 Observed standards.....	15
▪ 2.2.1 Indications.....	7	◦ 10.6 Information and manufacturer's declaration concerning electromagnetic compatibility (EMC).....	15
▪ 2.2.2 Part of the body.....	7	▪ 10.6.1 General.....	15
▪ 2.2.3 Patient population.....	7	▪ 10.6.2 Emitted interference.....	16
▪ 2.2.4 Contraindications.....	7	▪ 10.6.3 Electromagnetic immunity environment tested (part 1).....	17
◦ 2.3 Principles of operation.....	7	▪ 10.6.4 Electromagnetic immunity environment tested (part 2).....	18
▪ 2.3.1 Operating environment.....	7	▪ 10.6.5 Recommended separation distances between portable and mobile RF communications equipment and this product.....	20
◦ 2.4 Clinical benefit.....	7		
• 3 Introduction	8		
◦ 3.1 Overview.....	8		
• 4 Device assembly / installation	9		
◦ 4.1 Microscope and illumination.....	9		
◦ 4.2 Power supply.....	9		
◦ 4.3 Regulating the clearance of the slit width controls.....	9		
• 5 Commissioning	9		
◦ 5.1 Switching on the device.....	9		
• 6 Operation	9		
◦ 6.1 Setting the eyepieces.....	9		
◦ 6.2 Preparing the patient.....	10		
◦ 6.3 Operating the device.....	10		
◦ 6.4 Setting the filters & diaphragms.....	11		
◦ 6.5 Fixation star.....	11		
◦ 6.6 Microscope and eyepiece.....	12		
• 7 Decommissioning	12		
• 8 Technical data	12		
◦ 8.1 Slit illumination.....	12		

1 Safety



DANGER!

Failure to comply with these instructions may result in material damage or pose a danger to patients or users.



WARNING!

These warnings must absolutely be complied with to guarantee safe operation of the product and to avoid any danger to users and to patients.



NOTE!

Important information, please read carefully.

1.1 Comments on these instructions for use



NOTE!

In these instructions for use the point is used as decimal separator.

1.2 Ambient conditions

Transport	Temperature	-40 °C	...	+70 °C
	Air pressure	500 hPa	...	1060 hPa
	Relative humidity	10 %	...	95 %
Storage	Temperature	-10 °C	...	+55 °C
	Air pressure	700 hPa	...	1060 hPa
	Relative humidity	10 %	...	95 %
Use	Temperature	+10 °C	...	+35 °C
	Air pressure	800 hPa	...	1060 hPa
	Relative humidity	30 %	...	90 %

1.3 Shipment and unpacking

- Before unpacking the device, check whether the packaging shows traces of improper handling or damage. If this is the case, notify the transport company that delivered the goods to you.
- Unpack the device together with a representative of the transport company. Make a report of any damaged parts. This report must be signed by you and by the representative of the transport company.
- Leave the device in the packaging for a few hours before unpacking it (condensation).
- Check the device for damage after it is unpacked.
- Return defective devices in the appropriate packaging.
- Store packaging material carefully so that it can be used for potential returns or when moving.
- The slit lamp and headrest must be installed on an electrically insulated, fireproof table top.
- The rail covers (a) prevent the slit lamp from tilting.
- Check that the connection parts of the accessories are in the correct position (screw connections, quick-release fasteners).

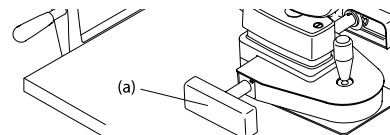

1.4 Installation warnings



WARNING!

- Do not modify this device without authorization of the manufacturer. Installation and repairs may only be performed by trained specialists.
- Any third-party device must be connected in compliance with the EN 60601-1 standard.
- Only original Haag-Streit spare parts may be used.

- Use of this device adjacent to or stacked with other equipment should be avoided because it could result in improper operation. If such use is necessary, this device and the other equipment should be observed to verify that they are operating normally.
- Grounding reliability can only be achieved when unit is connected to a hospital grade receptacle. (Not valid for EU countries).
- The device should be set up in such a way that the plug is always easily accessible and the device can easily be disconnected from the mains.

1.5 Operation, environment



DANGER!

Never use the device in potentially explosive environments where volatile solvents (alcohol, petrol, etc.) and flammable anaesthetics are in use.



WARNING!

- The device must be switched off after every use. Otherwise there is a risk of overheating when a protective dust cover is used.
- This device must not be operated near of high frequency surgical equipment and the radio frequency shielded room of a medical electrical system for magnetic resonance imaging, where the intensity of electromagnetic disturbances is high.
- Portable radio frequency communications equipment (including peripherals such as antenna cables and external antennas) should be used no closer than 30 cm (12 inches) to any part of the device, including cables specified by Haag-Streit. Otherwise, degradation of the performance of this device could result.



NOTE!

- This device must only be operated by qualified personnel. The owner is responsible for their training.

- This device may only be used in accordance with the instructions in the 'Intended purpose / intended use' chapter.

1.6 Light toxicity



WARNING!

- The light from this device may be dangerous. The risk of eye damage increases with the exposure time. An exposure time with this device at maximum intensity of longer than 152 seconds exceeds the guideline value for a risk.
- As extended, intensive illumination can damage the retina, the use of the device in the examination of the eye should not be prolonged unnecessarily. The illumination of this slit lamp emits a radiation in the range between 400 and 750 nm. Detailed information on the radiation can be provided on request.
- The retinal dose for a photochemical risk is composed of the product of the radiance and the exposure time. If the radiance is halved, the time until the exposure time limit value is reached will double accordingly. To date, no acute, optical radiation hazard has been detected in slit lamps. Nevertheless, we recommend keeping the intensity of the light reaching the patient's retina to the minimum possible for the respective diagnosis. Children, people with aphakia and people suffering from eye conditions are most at risk. An increased risk may also occur if the retina is exposed to the same or a similar device with a visible light source within 24 hours. This applies, in particular, if the retina has been photographed with a flashbulb in advance.

1.7 Disinfection



NOTE!

The device can, but does not need to be disinfected. For more information, please refer to the 'Maintenance' chapter.

1.8 Warranty and product liability

- Haag-Streit products must be used only for the purposes and in the manner described in the documents distributed with the product.
- The product must be treated as described in the 'Safety' chapter. Improper handling can damage the product. This would void all guarantee claims.
- Continued use of a product damaged by incorrect handling may lead to personal injury. In such a case, the manufacturer will not accept any liability.
- Haag-Streit does not grant any warranties, either expressed or implied, including implied warranties of merchantability or fitness for a particular use.
- Haag-Streit expressly disclaims liability for incidental or consequential damage resulting from the use of the product.
- This product is covered by a limited warranty granted by your seller.
- The optional T-Cone must be stored in its original dust cover and protected from direct sunlight.
- For USA only: This product is covered by a limited warranty, which may be reviewed at www.haag-streit-usa.com.

1.9 Reporting obligation



NOTE!

Any serious incident that has occurred in relation to the device must be reported to Haag-Streit and the competent authority of the Member State in your country.

1.10 Description of symbols



Follow instruction for use



Read the instructions for use attentively



General warning, read the accompanying documentation



European certificate of conformity



Date of manufacture



Manufacturer



Haag-Streit reference number



Serial number



Trademark of the manufacturer
Haag-Streit AG



Listed European Authorized
Representative



Testsymbol of TÜV Rheinland
with approval for INMETRO
Brasil



Notes on disposal, see the
'Disposal' chapter



Medical Device



MET Listed Mark with approval
for USA and Canada

2 Intended purpose / intended use

A slit lamp biomicroscope is intended for use in eye examination. It is used to aid in the diagnosis and documentation of diseases or trauma which affect the structural properties of the eye.

2.1 Device description

The devices of the slit lamp are made up of:

- Stereo biomicroscope
- Slit illumination
- Instrument base
- Headrest and chin rest

The illumination system and a biomicroscope are mounted to an instrument base operated by joystick. The single joystick allows horizontal and vertical displacement of the slit lamp across the examination table. Both elements, the illumination system and the biomicroscope, can be swiveled progressively across the pivot, independently of one another.

A sturdy headrest is attached to the table. Both the table and the chin rest are adjustable in height to provide a comfortable, yet sturdy examination position to the patient, outside of the device's range of motion. As this device operates non-invasively it only comes into contact with the patient at the chin rest and forehead band.

2.1.1 Intended users

Users are qualified medical professionals such as ophthalmologists, optometrists, opticians, nurses and researchers or other qualified specialists as permitted by local legislation.

2.2 Medical purpose

This device has the following medical purpose:

- Diagnosis and monitoring of diseases of the anterior segment of the eye
- Diagnosis and monitoring of injuries of the anterior segment of the eye
- Investigation of the anatomy and physiological or pathological state of the anterior segment of the eye

2.2.1 Indications

The use of the slit lamp is indicated for the following medical conditions:

- Local and systemic diseases affecting the eye
- Lesions and defects of the anterior segment
- Acute infections and inflammations
- Presence of intraocular foreign bodies
- Other traumata of the eye

2.2.2 Part of the body

The slit lamp is intended for the examination of the human eye, specifically the anterior segment of the eye (i.e., lids, lashes, conjunctiva, cornea, anterior chamber, iris, and lens).

2.2.3 Patient population

This device is intended for use on human patients with the physical ability to sit in front of a slit lamp with their head resting against the headrest in a steady position and the mental ability to follow instructions.

2.2.4 Contraindications

There are no known contraindications.

2.3 Principles of operation

- The slit lamp implements the principle of focal illumination: The focal point of the microscope and the illumination coincide.
- The microscope arm and the illumination arm are mounted on an instrument base: Both can be swivelled independently around the same vertical axis.
- The instrument base can be moved in all three axes.
- When illuminating transparent media with a narrow, sharp slit, an 'optical section' can be magnified and viewed through the microscope.
- The patient's head is fixed to a height-adjustable headrest holder so that the examination can be carried out quickly and as comfortably as possible for both doctor and patient.

2.3.1 Operating environment

The slit lamp is intended to be used in professional health care facilities such as hospitals, physician's, optometrist's and optician's practices. For optimal use of the slit lamp, the ambient lighting should be attenuated to improve image contrast. In case of transillumination of the iris or for viewing details at great magnification at a narrow slit, it may be necessary to completely darken the room.

2.4 Clinical benefit

The use of the slit lamp allows for the systematic examination of the eye under magnification, thus permitting the diagnoses of pathologies that may have otherwise remained unidentified and could have lead to blindness if left untreated.

The clinical benefits of the product outweigh the remaining residual risks to the patient.

3 Introduction

The slit lamp consists of an illumination and a binocular microscope. The instrument base can be used to move the entire device in front of the eyes. The illumination offers a large number of setting options to make the practically invisible areas in the eye visible. There is also a range of accessories available for the slit lamp to allow special diagnosis possibilities in addition to the general examinations.

3.1 Overview

- | | |
|---|---|
| 1. Lamp cable | 16. Illumination arm locking screw |
| 2. Headrest | 17. Microscope arm locking screw |
| 3. Headband | 18. Slit width controls |
| 4. Height mark on headrest (patient eye) | 19. Slit length / diaphragm scale |
| 5. Adjustable fixation lamp | 20. Slit length, slit rotation, blue filter and fixation star control |
| 6. Chin rest | 21. Cover screw for accessories pin |
| 7. Height adjustment of chin rest | 22. Stereo microscope with eyepieces |
| 8. Diffusor | 23. Eyepieces |
| 9. Illumination head LED LI 900 (see separate instructions) | 24. Lens-changing lever |
| 10. Lever to change filter | 25. Mounting screw for the stereo microscope |
| 11. Scale for angled position of the slit image (5° increments) | 26. Centring screw |
| 12. Illumination mirror | 27. Inclination angle latch 0 - 20° |
| 13. Breath shield (option) | 28. Joy stick base locking screw |
| 14. Protective cover | 29. Rail cover |
| 15. Illumination unit / microscope angle scale | 30. Control lever |
| | 31. Slide plate |

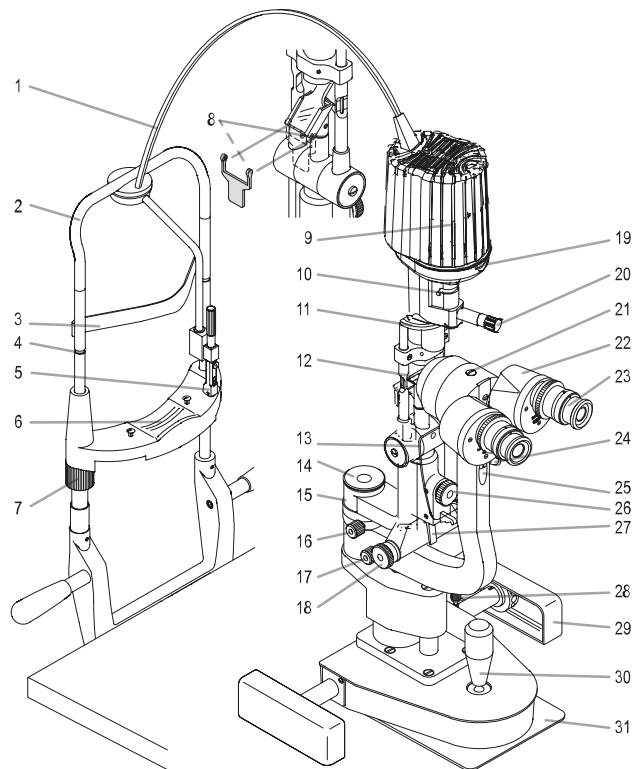

4 Device assembly / installation



WARNING!

- Do not modify this device without authorization of the manufacturer. Installation and repairs may only be performed by trained specialists.
- Contact your Haag-Streit representative for installation, repairs and modification work on the system. The contact details are available at www.haag-streit.com.
- Only original Haag-Streit spare parts may be used.

4.1 Microscope and illumination

- The slit lamp is packaged and delivered fully assembled. The transport safety devices must be removed prior to commissioning.

4.2 Power supply



NOTE!

- Observe the respective Haag-Streit instructions for use. For further information, please contact your Haag-Streit representative.
- This device must only be operated with PS-LED and PS-LED HSM 901 Haag-Streit power supplies and the RM02 release module.

4.3 Regulating the clearance of the slit width controls

The small screw in the centre of the right control knob (18) allows you to regulate the friction of the turning movement of these adjusting knobs. Turning it slightly to the right (in) makes it harder, turning it left (out) makes it easier. It should at least be set so hard that the slit cannot close on its own.

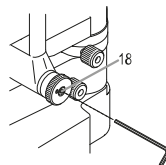

5 Commissioning

The device can be switched on and off using the mains power switch on the power supply. The green lamp in the rocker switch lights up when the device is switched on.

5.1 Switching on the device

- Connect the power supply to the mains and press the rocker switch. The green lamp in the rocker switch lights up when the device is switched on.
- Turn the rotating knob on the illumination control to a position between '1' and '10'.

6 Operation

6.1 Setting the eyepieces



NOTE!

The eyepieces must be individually set prior to the first examination in accordance with the refraction of the examiner. Insert the provided focus test rod (32) in place of the protective cover (14) and turn its black projection surface at a right angle to the microscope axis. Return the illumination and microscope to the central position (0°).

14. Protective cover
32. Test rod
33. Knurled ocular refraction ring with dioptre scale

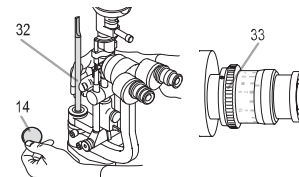

- Each eyepiece should be set individually by turning the knurled ocular refraction ring with dioptre scale (33) such that the projected slit can be seen in focus. The setting is performed from the (+) to the (-) side at low magnification.
- The pupil distance should then be set on the microscope.

6.2 Preparing the patient

- In order to attain a solid basis for the forehead and chin to rest on, the table height should be selected such that the patient sits bent over forward.
- To ensure that only the part of the eye being examined is illuminated, the slit height should be set accordingly in order to avoid distracting streaking of light.
- Applied parts which come into contact with the patient (headrest) should be disinfected prior to every use (see instructions for use 'Headrest').
- The slit lamp must be switched off after every examination in accordance with the 'Decommissioning' chapter.

6.3 Operating the device



WARNING!

The device must be switched off after every use. Otherwise there is a risk of overheating when a protective dust cover is employed.

- Use the turn screw (7) to set the chin rest (6) in such a way that the patient's eyes are at the same height as the black mark (4) on the sides of the headrest.
- Adjust the eyepieces (23) in accordance with the examiner's refraction by turning the knurled rings and set the eye distance.
- Switch on the illumination by turning the switch on the power supply.
- Adjust the height of the slit lamp by turning the control lever (30) until the light beam and microscope axis are at eye level.
- The rigid control lever (30) gently inclined towards the examiner can be used to push the entire device until the slit appears approximately focused on the cornea. This initial setting is verified with the naked eye. Fine tuning is performed by tilting the control lever, which is easily controlled at the top end, while observing via the stereo microscope (22).
- The slit width is set left or right with the rotating knob (17), as is the angle between the stereo microscope and illumination.
- The slit image can be set vertically, horizontally or as diagonally as required by turning the illumination facility on the control knob (20) (locking points at 45°, 90° and 135°; stops at 0° and 180°; scale in 5° increments).
- To ensure that unimpeded binocular fundus examination in the optical section is also possible at lateral angles of between 3° and 10°, a short mirror (12) is used, the illumination turned 90° using the locking screw (20) and tilted in 5°

steps using the latch (27), and the illumination and microscope turned to the central position (0°).

- The magnification of the stereo microscope can be changed on the slit lamp BM 900 by changing the lenses using the lever (24) or exchanging the eyepieces.
- Front lenses and contact lenses are used to examine the ocular fundus.

Diffuse illumination:

Connecting the diffusor (8) upstream creates diffused illumination. This allows monitoring of the overview and can be used to capture the overview with an imaging module.

Indirect illumination:

For observation in regredient light (indirect illumination), the centring screw (26) is loosened in order to move the slit image out of the centre of the visual field. Tightening the screw centres the slit image again.

Slit tilting:

The latch (27) can be used to tilt the illumination in 5° steps. This creates an angled light beam during horizontal slit orientation. Tilting the slit enables reflex-free examination with contact lenses (fundus and gonioscopy) and magnifying lenses.

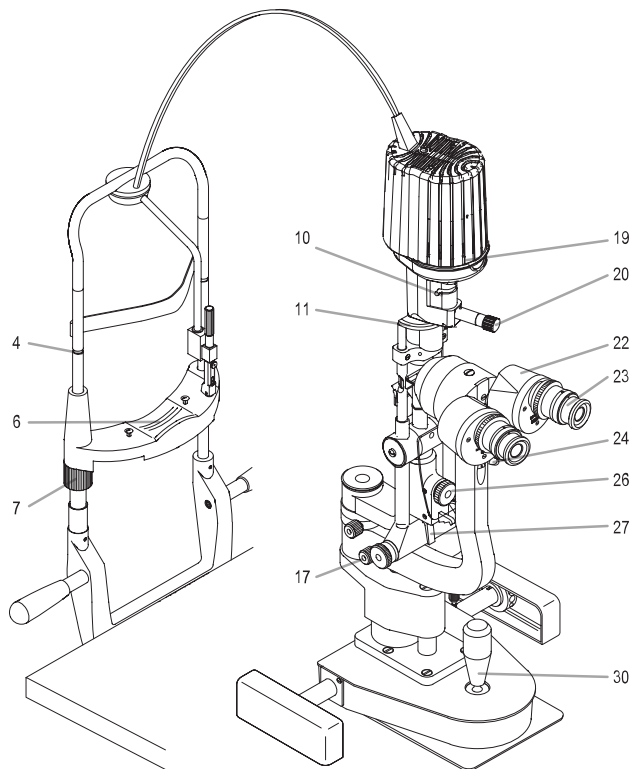

6.4 Setting the filters & diaphragms

- Open
- Grey filter (10%)
- Red removal filter
- Reserve opening for filter of choice \varnothing 15 mm (0 / -0.2), thickness 2.5 mm
- Fixation star (predominantly used for fixation examination of cross-eyed children with amblyopia)
- Apertures of \varnothing 8, 5, 3, 2, 1 and 0.2 mm
- Display of slit length adjustment from 1 to 8 mm
- Blue filter

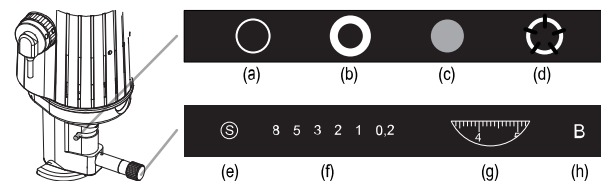

6.5 Fixation star

- Turning the diaphragm disc as far as it will go to the left switches on the fixation star and the symbol "S" appears in the window. In some examinations of the fundus, this star is projected onto the ocular fundus and is also visible to the patient, who is asked to focus on the centre hole of the star. This allows the examiner to see where the patient's vision is most focused.
- A typical use of the fixation star is during laser treatments close to the macula. Similarly, it is also possible to identify microstrabismus with the projection of the fixation star. The fixation star is usually used with an upstream red removal filter.



6.6 Microscope and eyepiece

The magnification of the microscope can be altered by changing the lens mounted in a revolving turret piece or by exchanging the eyepieces. Only the lever (40) is to be adjusted, from 1× to 1.6×, when changing the lens. In this instance, the examination need not be interrupted; nor is a new adjustment of the microscope needed. This change will alter the overall magnification from 10× to 16× (on the 10× eyepiece) and from 25× to 40× (on the 25× eyepiece) respectively.

- 34. Magnification changing lever
- 35. Prism housing
- 36. Eyepiece mounting
- 37. Dioptre scale for 16× eyepieces for setting the refraction of the examiner (± 8 D)
- 38. Dioptre scale for 10× eyepieces for setting the refraction of the examiner (± 8 D)
- 39. Index (white point)
- 40. 10× or 25× eyepiece

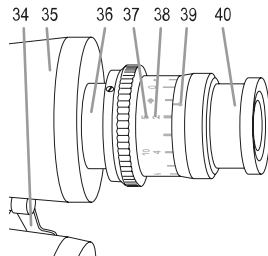

7 Decommissioning

The LED illumination can be switched off with the illumination controls. The power supply remains switched on during this process and the switch lights up green. To switch off the system completely, the rocker switch must be set to position 0 = 'OFF'. This creates a two-pole isolation from the mains.



NOTE!

Disconnect the power supply from the mains if you do not intend to use it for an extended period of time.

8 Technical data

8.1 Slit illumination



NOTE!

Detailed information regarding the radiation can be provided on request.

Spectral range slit illumination	400 to 750 nm
Spectral range background illumination	400 to 750 nm
Slit image width	0 – 8 mm continuous
Slit image length	1 – 8 mm continuous
Illumination field circle	\varnothing 8 / 5 / 3 / 2 / 1 / 0.2 mm
Test mark	With fixation star
Slit image rotatability	0 – 90°
Inclination of slit illumination to microscope axis	Horizontal $\pm 90^\circ$, vertical 0 – 20°
Filters	Blue, red removal (green), grey (10%)



NOTE!

Further information is available in the LED illumination LI 900 instructions for use.

8.2 Stereo microscope

Stereo angle:	13°
Magnification changer:	1× and 1.6×
Magnif. with 10× eyepiece	10× and 16× (standard)
Magnif. with 25× eyepiece	25× and 40×

Range of adjusting eye-pieces	+8 to -8 dioptres
Pupil distance	54 – 94 mm
Lens	1× / 1.6× / 1× / 1.6×
Eyepiece	10× / 10× / 25× / 25×
Total magnification	10× / 16× / 25× / 40×
Object field diameter	18 mm / 11.3 mm / 8 mm / 5 mm

8.3 Instrument base

Operation:	Single-handed operation of control lever in three dimensions
Adjustment of instrument base:	100 mm (length), 100 mm (side), 30 mm (height)

8.4 Dimensions

Weight:	11.4 kg (without power supply, headrest and options)
Dimensions L × W × H:	290 × 332 × 700 mm
Packaging L × W × H:	420 × 510 × 780 mm

9 Maintenance



WARNING!

- Do not modify this device without authorization of the manufacturer. Installation and repairs may only be performed by trained specialists.
- Contact your Haag-Streit representative for installation, repairs and modification work on the system. The contact details are available at www.haag-streit.com.
- Only original Haag-Streit spare parts may be used.

The LED illumination can be operated maintenance-free for its entire service life.

9.1 Device inspection

In order to correctly check the slit lamp, proceed as follows:

- Insert the test rod into the radial movement bearing, whilst at the same time aligning the surface to the microscope at a right angle.
- Set the slit length to 8 mm.
- Set the illumination intensity to 50%.
- Set the magnification in the microscope to max.
- Set the eyepieces in such a way that the test rod is in sharp focus. In doing so, turn the ocular from the (+) to the (-) side.
- For all magnifications, the structure of the test rod must be shown in sharp focus.
- Close the slit edges to approx. 0.5 mm. The edges must be shown in sharp focus.
- Open the slit edges completely and turn the test rod by 45°, the sharp area must be in the centre of the test rod.

9.2 Servicing

To guarantee a long service life, the device must be cleaned weekly as described and protected with the dust cover when not in use. We recommend having the device inspected once a year by an authorized service technician.

9.3 Cleaning and disinfection

The Haag-Streit slit lamps and their accessories can, if required, be carefully wiped down with ready-for-use disposable 70% ethanol disinfectant wipes. Surface-friendly disinfectants (containing aldehyde or aldehyde-free) are also permitted, such as Kohrsolin FF.



WARNING!

- The preparation instructions provided do not apply to tonometer measuring prisms.
- Tonometer measuring prisms must be prepared in accordance with a different manual.
- Too strong or aggressive disinfectants or cleaning liquids e.g. hydrogen peroxide will damage the finish and coating of the device.
- Do not use sprays.

- Observe the manufacturer's safety instructions.
- Do not use any cloths that drip.
- Wring out any soaked cloths before use when necessary.
- Ensure that no liquid penetrates the device.
- Comply with the stipulated exposure time.
- Clean optical surfaces after disinfection with a very soft cloth.

**NOTE!**

IP code: IPX0 (device is not protected against liquids)

9.4 Replacing the illumination mirror

The mirror can be most easily accessed if the microscope is turned away from the illumination and the illumination inclined two points.

**WARNING!**

Only use mirrors with a LOT number.

9.5 Dust cover

We recommend protecting the slit lamp with a dust cover when not in use.



10 Appendix

**WARNING!**

- Do not modify this device without authorization of the manufacturer. Installation and repairs may only be performed by trained specialists.
- Contact your Haag-Streit representative for installation, repairs and modification work on the system. The contact details are available at www.haag-streit.com.
- Only original Haag-Streit spare parts may be used.

10.1 Accessories / functionals parts / detachable parts / consumables

Components	REF
Eyepiece 10 × with reticule for estimating length and angle	1400265
Eyepiece 25 ×	1400337
Eyepiece 25 × with McIntyre comparison grid	1400340
Fixation base with screw AT 900 Type R for slit lamp BM 900	1022449
Short mirror	1001591
Breath shield (slit lamp BQ/BM/BP)	1007129
Fine brush for cleaning the optics	1001398
Diagnostic contact lenses	Please refer to the instructions for use 'Contact lenses, Goldmann/Diagnostics/Laser'
Applanation Tonometer	Please refer to the instructions for use 'Applanation tonometer AT 900 / AT 870' and 'Applanation tonometer AT 900 D'
Headrest	Please refer to the instructions for use 'Headrest'

10.2 Legal regulations

- This device was developed and designed taking the EN 60601-1, EN ISO 10939 and EN ISO 15004-2 standards into account.
- The EN 60601-1 standard must be observed when using different medical and/ or non-medical electrical devices in combination.
- Compliance of the device with the Medical Device Regulation 2017/745 is confirmed by the CE-designation.
- The device satisfies the electromagnetic compatibility requirements of EN 60601-1-2. The device has been designed to maintain the emissions of electromagnetic interference at a level which does not exceed the statutory guidelines and which does not affect other devices in its vicinity.
- The device also has the immunity stipulated by the standard.
- You can request a copy of the declaration of conformity for this device from Haag-Streit at any time.
- Statutory accident regulations are to be observed.

10.3 Classification

Standard EN 60601-1	Protection class I
Operating mode	Continuous operation
CE Medical Device Regulation 2017/745	Class I
FDA	Class II

10.4 Disposal

Electrical and electronic devices must be disposed of separately from household waste! This device was made available for sale after the 13th August 2005. For correct disposal, please contact your Haag-Streit representative. This will guarantee that no hazardous substances enter the environment and that valuable raw materials are recycled.



10.5 Observed standards

EN 60601-1
 EN 60601-1-2
 EN ISO 10939
 EN ISO 15004-2

10.6 Information and manufacturer's declaration concerning electromagnetic compatibility (EMC)

10.6.1 General

This device fulfills the requirements on electromagnetic compatibility according to IEC 60601-1-2:2014 (4th Edition). The device is built so that the generation and emission of electromagnetic interference is limited to the extent that other devices are not disturbed in their use in accordance with the regulations and so that the device itself is suitably immune to electromagnetic interference.



WARNING!

- Electrical medical devices and systems are subject to special EMC measures and must be installed in accordance with the EMC instructions contained in this accompanying document.
- Use of accessories, transducers and cables other than those specified or provided by Haag-Streit could result in increased electromagnetic emissions or decreased electromagnetic immunity of this device and result in improper operation.
- Third-party devices may only be connected in compliance with the IEC 60601-1 standard.

10.6.2 Emitted interference

This product is intended for use in the electromagnetic environment specified below. The customer or the user of this product should assure that it is used in such an environment.

Emission test	Compliance	Electromagnetic environment - guidance
RF emissions CISPR 11	Group 1	This product uses RF energy only for its internal function. Therefore, its RF emissions are very low and are not likely to cause any interference in nearby electronic equipment.
RF emissions CISPR 11	Class B	This product is suitable for use in all establishments, including domestic establishments and those directly connected to the public low-voltage power supply network that supplies buildings used for domestic purposes.
Harmonics emissions IEC 61000-3-2	Not applicable	
Voltage fluctuations/flicker emissions IEC 61000-3-3	Not applicable	

10.6.3 Electromagnetic immunity environment tested (part 1)

This product is intended for use in the electromagnetic environment specified below. The customer or the user of this product should assure that it is used in such an environment.

Immunity test	IEC 60601 test level	Compliance level	Electromagnetic environment – guidance
Electrostatic discharge (ESD) IEC 61000-4-2	± 8 kV contact ± 2, ± 4, ± 8, ± 15 kV air	± 8 kV contact ± 2, ± 4, ± 8, ± 15 kV air	Floors should be wood, concrete or ceramic tile. If floors are covered with synthetic material, the relative humidity should be at least 30%.
Electrical fast transient/burst IEC 61000-4-4	± 2 kV, 100kHz for power supply lines * ± 1 kV, 100 kHz for input/output lines *	± 2 kV, 100kHz for power supply lines * ± 0.5, ± 1 kV, 100 kHz for input/output lines *	Mains power quality should be that of a typical commercial or hospital environment. * Not applicable for DC and I/O if cable < 3 m.
Surge IEC 61000-4-5	± 0.5, ± 1 kV line(s) to line(s) * ± 0.5, ± 1, ± 2 kV line(s) to earth *	± 1 kV line(s) to line(s) * ± 0.5, ± 1, ± 2 kV line(s) to earth *	Mains power quality should be that of a typical commercial or hospital environment. * Not applicable for DC and I/O if cable < 3 m.
Voltage dips, short interruptions and voltage variations on power supply input lines IEC 61000-4-11	0% U _T : 0.5 cycle at 0°, 45°, 90°, 135°, 180°, 225°, 270° and 315° 0% U _T : 1 cycle at 0° 0% U _T : 250/300 cycles at 0° 70% U _T : 25/30 cycles at 0°	0% U _T : 0.5 cycle at 0°, 45°, 90°, 135°, 180°, 225°, 270° and 315° 0% U _T : 1 cycle at 0° 0% U _T : 250/300 cycles at 0° 70% U _T : 25/30 cycles at 0°	Mains power quality should be that of a typical commercial or hospital environment. If the user of this product requires continued operation during power mains interruptions, it is recommended that this product be powered from an uninterruptible power supply or battery. U _T is the a.c. mains voltage (100 – 240 V) prior to application of the test level.
Power frequency (50/60 Hz) magnetic field IEC 61000-4-8	3 A/m 50/60 Hz	30 A/m 50/60 Hz	Power frequency magnetic fields should be at levels characteristic of a typical location in a typical commercial or hospital environment.

10.6.4 Electromagnetic immunity environment tested (part 2)

Portable and mobile RF communications equipment should be used no closer to any part of this product, including cables, than the recommended separation distance calculated from the equation applicable to the frequency of the transmitter.

These guidelines may not apply in all situations. Electromagnetic propagation is affected by absorption and reflection from structures, objects and people. Field strengths from fixed transmitters, such as base stations for radio (cellular/cordless) telephones and land mobile radios, amateur radio, AM and FM radio broadcast and TV broadcast cannot be predicted theoretically with accuracy. To assess the electromagnetic environment due to fixed RF transmitters, an electromagnetic site survey should be considered.

Immunity test	IEC 60601 test level	Compliance level	Electromagnetic environment - guidance
Conducted RF IEC 61000-4-6	3 V _{rms} 150 kHz – 80 MHz outside ISM bands and radio amateur band *	3 V _{rms} 150 kHz – 80 MHz outside ISM bands and radio amateur band *	If the measured field strength in the location in which this product is used exceeds the applicable RF compliance level, this product should be observed to verify normal operation. If abnormal performance is observed, additional measures may be necessary, such as reorienting or relocating this product.
	6 V _{rms} 150 kHz – 80 MHz in ISM bands and radio amateur band *	6 V _{rms} 150 kHz – 80 MHz in ISM bands and radio amateur band *	
Radiated RF IEC 61000-4-3	3 V/m 80 MHz – 2.7 GHz 80% AM 1 kHz	3 V/m 80 MHz – 6 GHz 80% AM 1 kHz	Minimum separation distance shall be calculated by following equation: $E = \frac{6}{d} \sqrt{P}$
Proximity field from RF wireless communication equipment IEC 61000-4-3	27 V/m 380 – 390 MHz 50% PM 18 Hz	27 V/m 380 – 390 MHz 50% PM 18 Hz	E is the immunity test level in [V/m] d is the minimum separation in [m] P is the maximum power in [W]
	28 V/m 430 – 470 MHz FM ± 5 kHz deviation, 1kHz sine	28 V/m 430 – 470 MHz FM ± 5 kHz deviation, 1kHz sine	
	9 V/m 704 – 787 MHz 50% PM 217 Hz	9 V/m 704 – 787 MHz 50% PM 217 Hz	RF wireless equipment maximum output power and separation distance tested (at 30 cm): TETRA 400: max 1.8 W GMRS 460, FRS 460: max 2 W LTE Band 13 and 17: max 0.2 W GSM 800/900: max 2 W TETRA 800: max 2 W iDEN 820: max 2 W
	28 V/m 800 – 960 MHz 50% PM 18 Hz	28 V/m 800 – 960 MHz 50% PM 18 Hz	

28 V/m
1700 – 1990 MHz
50% PM 217 Hz

28 V/m
2400 – 2570 MHz
50% PM 217 Hz

9 V/m
5100 – 5800 MHz
50% PM 217 Hz

28 V/m
1700 – 1990 MHz
50% PM 217 Hz

28 V/m
2400 – 2570 MHz
50% PM 217 Hz

9 V/m
5100 – 5800 MHz
50% PM 217 Hz

CDMA 850: max 2 W
LTE Band 5: max 2 W
GSM 1800/1900: max 2 W
CDMA 1900: max 2 W
DECT: max 2 W
LTE Band 1, 3, 4, 25: max 2 W
UMTS: max 2 W
Bluetooth: max 2 W
WLAN 802.11b/g/n: max 2 W
RFID 2450: max 2 W
LTE Band 7: max 2 W
WLAN 802.11 a/n: max 0.2 W

Interference may occur in the vicinity of equipment marked with the following symbol:



* The ISM (industrial, scientific and medical) bands between 150 kHz and 80 MHz are: 6.765 – 6.795 MHz, 13.553 – 13.567 MHz, 26.957 – 27.283 MHz, 40.66 – 40.7 MHz. The amateur radio bands between 0.15 MHz and 80 MHz are: 1.8 MHz – 2 MHz, 3.5 – 4.0 MHz, 5.3 – 5.4 MHz, 7 – 7.3 MHz, 10.1 – 10.15 MHz, 14 – 14.2 MHz, 18.07 – 18.17 MHz, 21.0 – 21.4 MHz, 24.89 – 24.99 MHz, 28.0 – 29.7 MHz, 50.0 – 54.0 MHz.

If the measured field strength in the location in which this product is used exceeds the applicable RF compliance level above, this product should be observed to verify normal operation. If abnormal performance is observed, additional measures may be necessary, such as reorienting or relocating this product.

10.6.5 Recommended separation distances between portable and mobile RF communications equipment and this product

This product is intended for use in the electromagnetic environment in which radiated RF disturbances are controlled. The customer or the user of this product can help prevent electromagnetic interference by maintaining a minimum distance between portable and mobile RF communications equipment (transmitters) and this product as recommended below, according to the maximum output power of the communication equipment.

Rated maximum output power of transmitter [W]	Separation distance according to frequency of transmitter [m]		
	150 kHz – 80 MHz outside ISM and radio amateur bands * d = 1.2 √P **	150 kHz – 80 MHz in ISM and radio amateur bands * d = 2.0 √P	800 MHz – 2.7 GHz (for define RF Wireless transmitters see table before) d = 2.0 √P
0.01	0.12	0.20	0.20
0.1	0.38	0.63	0.63
1	1.2	2.0	2.0
10	3.8	6.3	6.3
100	12	20	20

For transmitters rated at a maximum output power not listed above, the recommended separation distance d in metres [m] can be determined using the equation applicable to the frequency of the transmitter, where P is the maximum output power rating of the transmitter in watts [W] according to the transmitter manufacturer.

$$E = \frac{6}{d} \sqrt{P}$$

* The ISM (industrial, scientific and medical) bands between 150 kHz and 80 MHz are: 6.765 – 6.795 MHz, 13.553 – 13.567 MHz, 26.957 – 27.283 MHz, 40.66 – 40.7 MHz. The amateur radio bands between 0.15 MHz and 80 MHz are: 1.8 MHz – 2 MHz, 3.5 – 4.0 MHz, 5.3 – 5.4 MHz, 7 – 7.3 MHz, 10.1 – 10.15 MHz, 14 – 14.2 MHz, 18.07 – 18.17 MHz, 21.0 – 21.4 MHz, 24.89 – 24.99 MHz, 28.0 – 29.7 MHz, 50.0 – 54.0 MHz.

** Formulas coming from Edition 3 of the IEC 60601-1-2.

Should you have any further questions, please contact your Haag-Streit representative at:
<http://www.haag-streit.com/contact/contact-your-distributor.html>

**HAAG-STREIT AG**

Gartenstadtstrasse 10
3098 Koeniz, Switzerland

Phone

+41 31 978 01 11

Fax

+41 31 978 02 82

eMail

info@haag-streit.com

Internet

www.haag-streit.com