

VANTAGE WIRELESS INDIRECT OPHTHALMOSCOPE

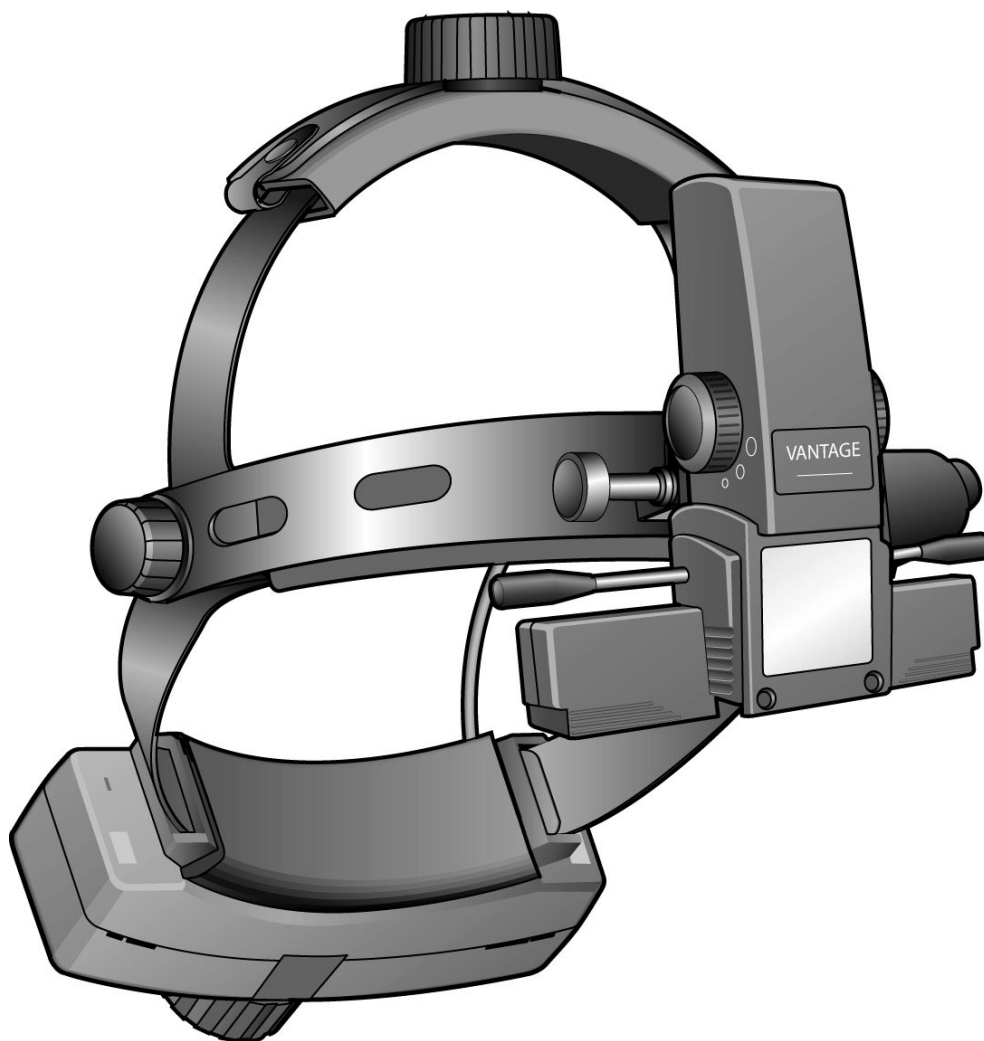

PLEASE READ AND FOLLOW THESE INSTRUCTIONS CAREFULLY



CONTENTS

1. Symbols
2. Warnings & Cautions
3. Environmental
4. Description of Product
5. Inserting / Replacing Batteries
6. Wall Mounting
7. Charging
8. Charging Cycle
9. Warranty & Service
10. Technical Information
11. Cleaning Instructions
12. Contact Details

1.0 Symbols



Attention. Read operating manual for cautions and instructions for use



The CE mark on this product indicates it has been tested to and conforms with the provisions noted within the 93/42/EEC Medical Device Directive

2.0 Warnings & Cautions

Carefully read this instruction section before using your Keeler product. For your own safety and that of your customers observe all cautionary information provided in this section. The following information is intended to highlight potential safety hazards that can be associated with misuse, or damage.



Warning

This product must not be used in the presence of flammable gases.

Do not disassemble or modify the battery. There are no serviceable parts inside.

Do not dispose of battery in fire, puncture or short circuit.

Do not use a battery that is deformed, leaking, corroded or visually damaged. Handle a damaged or leaking battery with extreme care. If you come into contact with electrolyte, wash the exposed area with soap and water. If it contacts the eye, seek medical attention immediately.

If the product emits a strange odour, heat or smoke, stop use immediately. The continued use of a damaged product or part may cause injuries.

Do not immerse the unit in any liquid.

Do not use unit if damaged and periodically visually inspect for signs of damage.

Do not fit in damaged mains socket.

In the event of poor contact, pins can get hot. Care should be taken when removing.

Avoid trailing cables as potential trip hazards.

Federal law restricts this device to sale by or order of a physician.



Caution

Use only Keeler battery part number 1919-P-1013

Charge only using Keeler charger – part number 1941-P-5334

Do not charge battery in any environment where the temperature may exceed 40° C or fall below 0°C.

Keep out of reach of children

For indoor use only (protect from moisture)

To prevent condensation from forming, allow instrument to come to room temperature before use.

When replacing Lithium battery pack, turn indirect off and attach a new pack.

Electrical equipment can be effected by electromagnetic interference. If this occurrence happens whilst using this equipment, switch the unit off and reposition.

3.0 Environmental

Dispose of battery in line with local regulations on recycling batteries.

Tape over battery contacts to avoid short circuiting during disposal.

Li-ion batteries contain no toxic heavy metals, such as mercury, cadmium or lead.

4.0 Description of Product

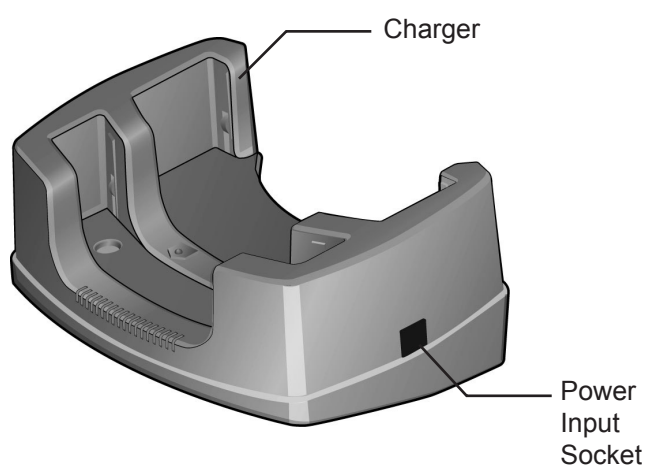
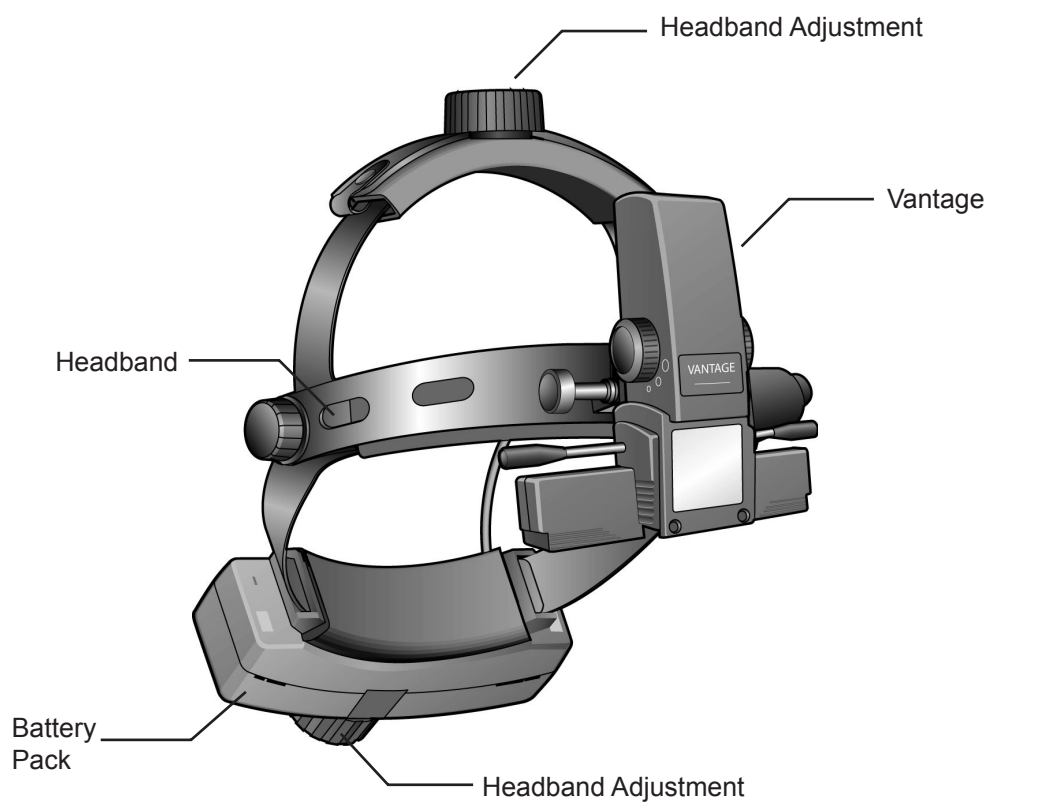

5.0 Inserting/Replacing Battery Pack

Release battery by pressing release switch as shown and lift battery pack from cradle.

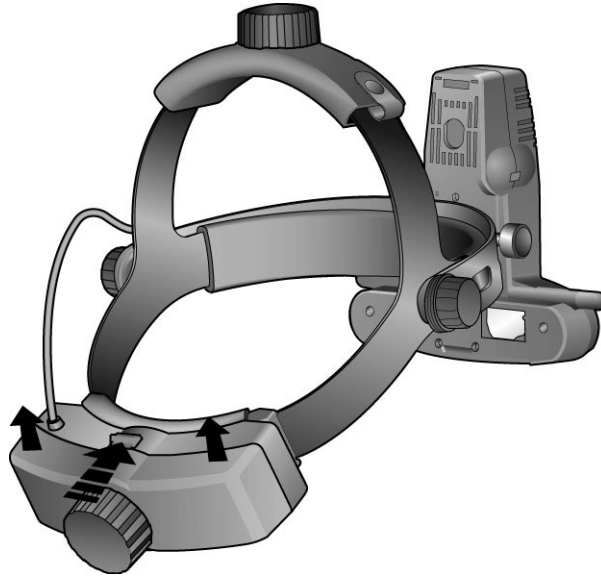

(API2 shown)

To insert new battery pack, place in cradle until fully engaged.

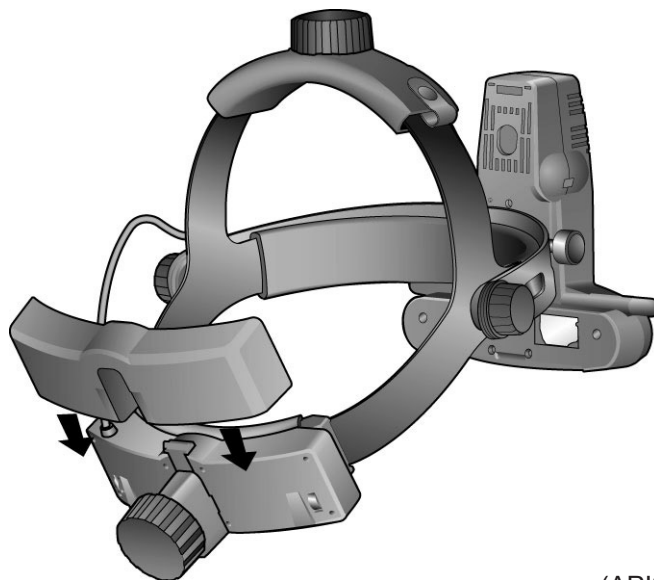

(API2 shown)

6.0 Wall Mounting

6.1

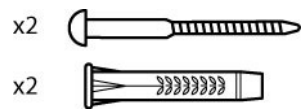

6.2

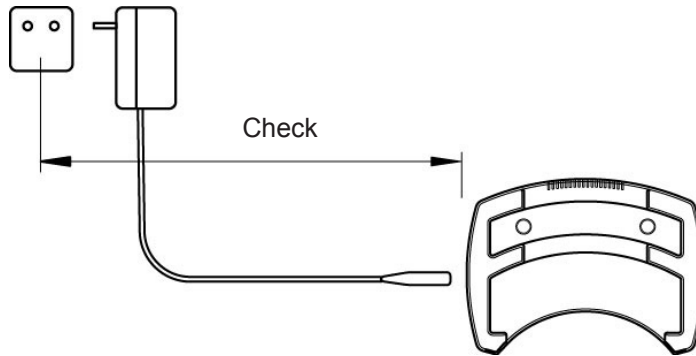

6.3

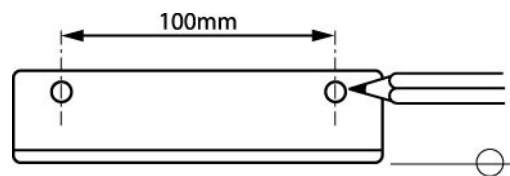

6.4 CAUTION

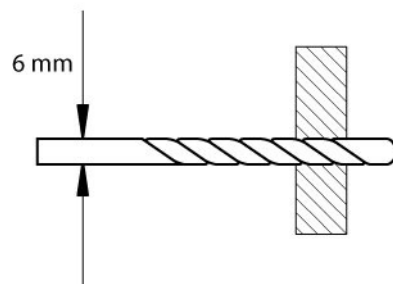
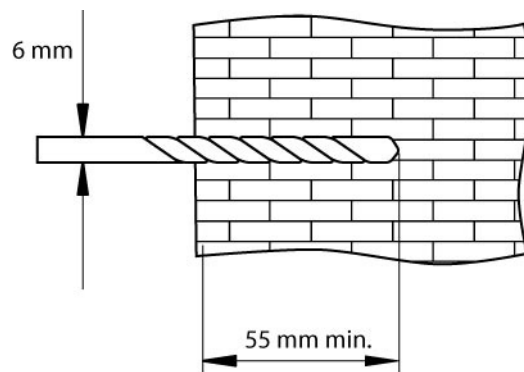

6.5

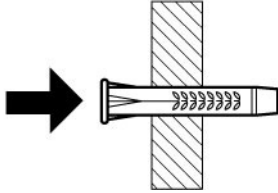
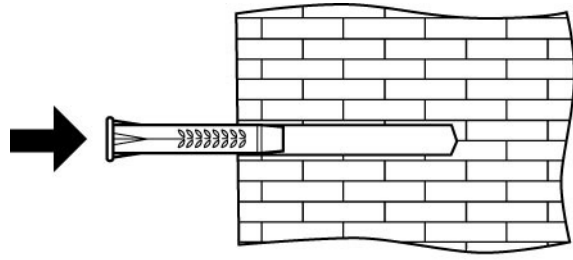

7.0 Charging

Replace the blanking plate with the appropriate mains plug adapter, and connect plug on cable to power input socket on charger.

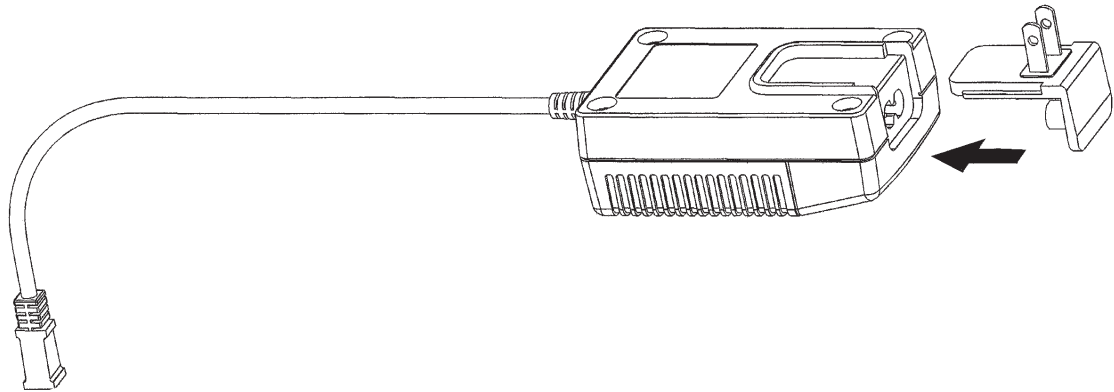

Switch on your Lithium Charger by plugging it into a mains outlet. Place your spare battery pack or headset into your Lithium Charger as shown.

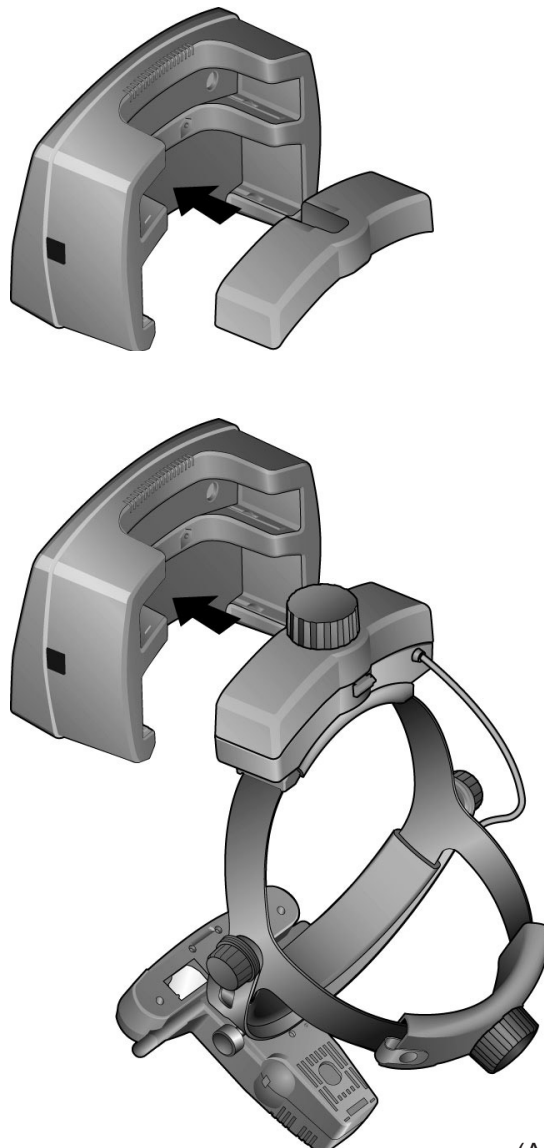

(API2 shown)

Lithium Battery

Flashing LED - Battery requires charging.

Charging Station

No LED - Battery is fully charged.

Flashing LED - Top up charge.

Solid LED - Rapid Charge.

The battery pack can be used at any time during the charging cycle and will automatically resume charging when battery pack is placed back in the charger.

Direction arrow on charger indicates which battery is being charged. (probably requires a drawing of some kind).

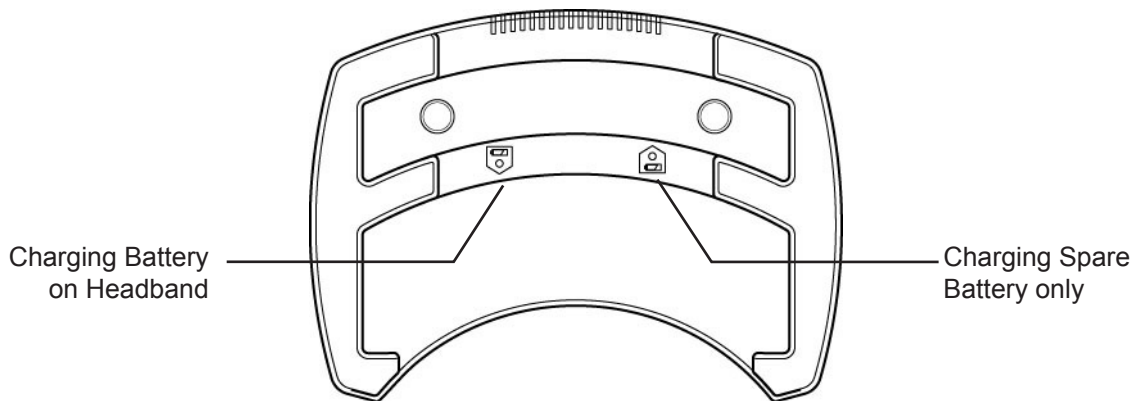

8.0 Charging Cycle

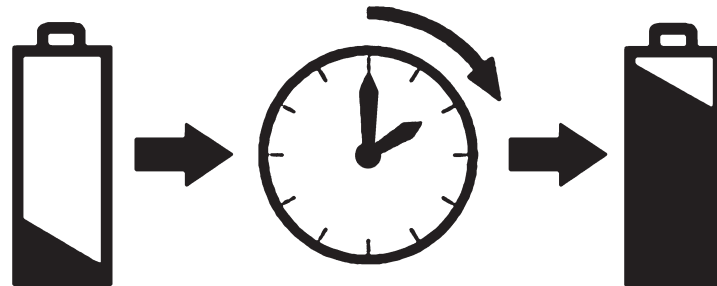

The battery attached to the indirect will take approximately 2 hours to fully charge.

The battery will last approximately 1 hours on full power.

The spare battery will take 4 hours to charge - 1919-P-1013.

9.0 Warranty & Service

No user serviceable parts – all preventative maintenance and servicing must only be performed by authorised Keeler representatives.

Your Keeler Charger is guaranteed for 3 years and will be replaced or repaired free of charge subject to the following:-

- 9.1 Any fault is due to faulty manufacture.
- 9.2 The power supply has been used in compliance with these instructions.
- 9.3 Proof of purchase accompanies any claim.

Batteries are guaranteed for 1 year from date of purchase.

10.0 Technical Information

Input data see name plate:

Power Supply Rating:

Operation:

Classification:

Safety Class:

Ambient Temperature:

Transportation:



100-240V - 50/60Hz

12V : 2.5 Amps

Continuous

Class II equipment

Type B Protection against electric shock

Double insulated

+10°C to +35°C

-40°C to +70°C 10% to 95% RH

Standards:

IEC60601-1 Electrical Safety / IEC 60601-1-2 EMC

ISO9022-2 Environmental

ISO9022-3 Environmental

11.0 Cleaning Instructions

Only manual non-immersion cleaning as described below should be used for the instrument.

- 11.1 Wipe the external surface with a clean absorbent, non shedding cloth dampened with a water / detergent solution (2% by volume) or water / isopopyl alcohol solution (70% by volume).
- 11.2 Ensure that excess solution does not enter the instrument. Use caution to ensure cloth is not saturated with solution.
- 11.3 Surfaces should be carefully hand-dried using a clean non-shedding cloth.
- 11.4 Safely dispose of used cleaning materials.

12.0 Contact Details

MANUFACTURED IN THE UK BY:

Keeler Limited

Clewer Hill Road

Windsor

Berkshire SL4 4AA

England

Tel: +44 (0)1753 857177

Fax: +44 (0)1753 827145

FREEPHONE: 0800 521 251

DISTRIBUTED BY:

Keeler Instruments Inc

456 Parkway

Broomall

PA 19008, USA

Toll Free: 1 800 523 5620

Tel: 610 353 4350

Fax: 610 353 7814

As part of our policy of continued product improvement we reserve the right to alter and/or amend specifications at any time without prior notice.

EP59-11197 Issue A