

INSTALLATION AND OPERATING INSTRUCTIONS

OWNERS MANUAL

MODEL 710 CHAIR/TABLE LOW VOLTAGE CONTROL

For *Designer* **SERIES** and **Premiere** **COLLECTION** Models



Reliance®
MEDICAL PRODUCTS, INC.

HS RELIANCE
INTERNATIONAL

SERIAL NUMBER

**For your future reference, mark the serial number
in the space provided.**



QUALITY MANAGEMENT
SYSTEM
REGISTERED TO
ISO 13485





TABLE OF CONTENTS

IMPORTANT INFORMATION.....	4	4. PROGRAMMING THE CHAIR.....	14
1. INTRODUCTION.....	5	4.1. Safety/Shutdown Feature.....	14
TECHNICAL SPECIFICATIONS.....	6	To ENTER Safety/Shutdown Mode.....	14
2. INSTALLATION.....	7	To EXIT Safety/Shutdown Mode.....	14
2.1. Unpacking.....	7	4.2. Individual Programming of the RAISE TOP,	
Chair.....	7	RECLINE TOP, RAISE BASE, and LOWER BASE switch	
2.2. Assembly.....	7	located on the Chair Back or Footswitch.....	14
Headrest.....	7	To ENTER Setup Mode	15
Power Receptacle.....	7	To EXIT Setup Mode.....	15
Setting Rotation Stop.....	7	4.3. BEEP-ON-SWITCH Feature.....	15
3. OPERATION.....	8	4.4. Auto Up/Retinal Feature.....	16
3.1. Stop Switch.....	8	To ENTER Auto Up/Retinal Mode.....	16
3.2. Chair Lift.....	8	To EXIT Auto Up/Retinal Mode.....	16
Raising & Lowering the Chair Lift with Membrane		4.5. Home Feature.....	16
Switches.....	8	To PROGRAM the Home Mode Feature.....	16
Raising & Lowering the Chair Lift from the		To UTILIZE the Home Mode Feature.....	16
Footswitch.....	8	To EXIT the Home Mode Feature.....	16
3.3. Chair Top.....	9	5. LOCATING AND REPLACING FUSES.....	17
Raising & Reclining the Chair Top with		5.1. Fuse Replacement.....	17
Membrane Switches.....	9	TROUBLESHOOTING GUIDE.....	18
Raising & Lowering the Chair Top From the		CLEANING AND MAINTENANCE	19
Footswitch.....	9	PARTS LIST.....	20
3.4. Automatic Return.....	11	Model 710 Chair Assembly (Designer).....	21
3.5. Memory Feature.....	11	Model 710 Chair Assembly (Premiere).....	22
Programming the Memory Feature.....	11	Chair Top Assembly.....	23
3.6. Revolving/Rotation.....	11	Chair Base Assembly.....	26
3.7. Arm Movement.....	11	Lift Assembly.....	28
3.8. Footrest.....	12	#18, 22 Headrest Assembly.....	30
3.9. Headrest.....	12	#10 Headrest Assembly.....	32
Operation-No. 18, 22 Headrest.....	12	#11 Headrest Assembly.....	34
Adjustment-No. 18, 22 Headrest.....	12	#21 Headrest Assembly.....	36
Operation-No.10, 30 Headrest	12	#20 Headrest Assembly.....	38
Operation-No.11, 21,31 Headrest	13	#27 Headrest Assembly.....	40
Adjustment-No. 11, 21,31 Headrest	13	C6 Headrest Assembly	42
Operation-No. 20 Headrest.....	13	#30 Headrest Assembly	44
Adjustment-No. 20 Headrest.....	13	#31 Headrest Assembly	46
Operation-No. 27 Headrest.....	13	Wiring Diagram - 710	48
Adjustment-No. 27 Headrest.....	14	LIMITED WARRANTY.....	51
Operation C6 Headrest.....	14		
Adjustment C6 Headrest.....	14		

IMPORTANT INFORMATION

SAFETY SYMBOLS

 **“DANGER”, “WARNING”, or “CAUTION”**
The exclamation point within an equilateral triangle is intended to alert the user to the presence of important operating and maintenance (servicing) instructions in this Installation and Operating Instructions.

 **« DANGER », « AVERTISSEMENT », ou « PRÉCAUTION »**
Le point d'exclamation à l'intérieur d'un triangle équilatéral vise à alerter l'utilisateur à la présence d'importantes instructions de fonctionnement et de maintenance (service) dans ce manuel d'installation et d'instructions de fonctionnement.

 **“NOTE”**
Amplifies a procedure, practice, or condition.

 **« REMARQUE »**
Amplifie une procédure, pratique ou condition.



Type B, Applied Part



Dangerous Voltage / Shock Hazard

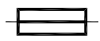

Fuse Rating Specification



Protective Earth Ground



Burn Hazard/Hot Surface



Alternating Current-AC



Safe Working Load



“Attention, Consult Accompanying Documents”



Refer to Instruction Manual/Booklet



Sitting Prohibited on Back of Chair

TRANSPORTATION / STORAGE CONDITIONS

Temperature: Operating: 59 to 104° F
15 to 40° C

Storage: -22 to +140° F
-30 to +60° C

Relative Humidity: Operating: 5 to 95% without condensation

Storage: 10 to 100% including condensation

Atmospheric Pressure:

Operating: 700hPa - 1060hPa

Storage: 500hPa - 1060hPa

1. INTRODUCTION

1.1. This manual contains information applicable only to the Reliance® Model 710 chair.

1.2. Whenever you see the symbols shown below, heed their instructions! Always follow safe operating and maintenance practices.



“DANGER”: THE DANGER SYMBOL IDENTIFIES SPECIAL INSTRUCTIONS OR PROCEDURES WHICH, IF NOT CORRECTLY FOLLOWED, COULD RESULT IN LOSS OF LIFE OR PERSONAL INJURY.



« DANGER » : LE SYMBOLE DANGER IDENTIFIE DES INSTRUCTIONS OU PROCÉDURES SPÉCIALES QUI, SI ELLES NE SONT PAS SUIVIES CORRECTEMENT, POURRAIENT CAUSER UNE PERTE DE VIE OU UNE BLESSURE.



“WARNING”: THE WARNING SYMBOL IDENTIFIES SPECIAL INSTRUCTIONS OR PROCEDURES WHICH, IF NOT CORRECTLY FOLLOWED, COULD RESULT IN PERSONAL INJURY.



« AVERTISSEMENT » : LE SYMBOLE AVERTISSEMENT IDENTIFIE DES INSTRUCTIONS OU PROCÉDURES SPÉCIALES QUI, SI ELLES NE SONT PAS SUIVIES CORRECTEMENT, POURRAIENT CAUSER UNE BLESSURE.



“CAUTION”: This caution symbol identifies special instructions or procedures which, if not strictly observed, could result in damage to or destruction of equipment.



« PRÉCAUTION » : Ce symbole de précaution identifie des instructions ou procédures spéciales qui, si elles ne sont pas strictement suivies, pourraient causer un dommage ou la destruction de l'équipement.



“NOTE”- Note indicates points of particular or additional information.



« REMARQUE » : Remarque indique des points d'intérêt particulier ou des renseignements additionnels.

1.3 Should your product not perform properly, or if you have any questions concerning the use and care of any Reliance® product, contact the Reliance® Distributor, where you purchased this product or contact the Technical Service Department, Reliance® Medical Products, Inc., 3535 Kings Mills Road, Mason, Ohio 45040-2303, or call (800) 735-0358.



NOTE: Always have the model number and serial number available before contacting Reliance® or your authorized Reliance® Distributor.



REMARQUE : Ayez toujours le numéro de modèle et le numéro de série à portée de la main avant de contacter Reliance® ou votre distributeur Reliance® autorisé

“CLASSIFIED BY CANADIAN STANDARDS ASSOCIATION® WITH RESPECT TO ELECTRIC SHOCK, FIRE AND MECHANICAL HAZARDS ONLY IN ACCORDANCE WITH UL 60601-1.”

According to Clause 5 in IEC 60601-1, sec 6.8.1, this unit is classified by the following:

- The type of protection against electric shock: EQUIPMENT energized from an external electrical power source: CLASS I EQUIPMENT
- The degree of protection against electric shock: TYPE B EQUIPMENT
- The degree of protection against harmful ingress of water: ORDINARY DEGREE
- The degree of safety of application in the presence of a FLAMMABLE ANAESTHETIC MIXTURE WITH AIR or WITH OXYGEN OR NITROUS OXIDE: EQUIPMENT not suitable for use in the presence of a FLAMMABLE ANAESTHETIC MIXTURE WITH AIR or WITH OXYGEN OR NITROUS OXIDE
- The mode of operation: CONTINUOUS OPERATION



WARNING: TO PREVENT FIRE OR SHOCK HAZARD, DO NOT EXPOSE THIS APPLIANCE TO RAIN OR MOISTURE.



AVERTISSEMENT : POUR ÉVITER UN INCENDIE OU UN RISQUE DE CHOC ÉLECTRIQUE, N'EXPOSEZ PAS CET ÉQUIPEMENT À LA PLUIE OU À L'HUMIDITÉ.

TECHNICAL SPECIFICATIONS

Rating for 120V Low Voltage Chair

This equipment is rated Class I, Type B

Equipment		Model
Low Voltage Chair		710
Volts	Hertz	Amps
120V	50/60	6.3
Class I	Type B	





ANSI / AAMI
ES60601-1: 2005
CAN / CSA-C22.2
NO. 60601-1-08

Rating for 220-240V Low Voltage Chair

This equipment is rated Class I, Type B

Equipment		Model
Low Voltage Chair		710
Volts	Hertz	Amps
220-240V	50/60	4.0
Class I	Type B	



ANSI / AAMI
ES60601-1: 2005
CAN / CSA-C22.2
NO. 60601-1-08



IMPORTANT USER WARNINGS



WARNING: EXPLOSION HAZARD. THIS EQUIPMENT MUST NOT BE USED IN THE PRESENCE OF FLAMMABLE ANESTHETICS.



AVERTISSEMENT : RISQUE D'EXPLOSION. CET ÉQUIPEMENT NE DOIT PAS ÊTRE UTILISÉ EN PRÉSENCE D'ANESTHÉSQUES INFLAMMABLES.

POTENTIAL ELECTROMAGNETIC or OTHER INTERFERENCE

This equipment generates, uses and can radiate radio frequency energy and, if not installed and used in accordance with the instructions, may cause harmful interference to other devices in the vicinity. However, there is no guarantee that interference will not occur in a particular installation.

If this equipment does cause harmful interference to other devices, which can be determined by turning the equipment off and on, the user is encouraged to try to correct the interference by one or more of the following measures:

- Reorient or relocate the receiving device.
- Increase the separation between the equipment.
- Connect the equipment into an outlet on a circuit different from that to which the other device(s) are connected.
- Consult the manufacturer or field service technician for help.



WARNING - STORAGE OF THIS EQUIPMENT BELOW 40°F (4.4°C) WILL CAUSE THE HYDRAULIC OIL TO BECOME THICK. THIS MAY CAUSE UNUSUAL NOISES WHEN THE BASE MOTOR IS OPERATED. IT IS RECOMMENDED THAT THE EQUIPMENT STAY AT A TEMPERATURE OF 60°F (15°C) OR ABOVE FOR AT LEAST 8 HOURS BEFORE OPERATING.



AVERTISSEMENT : L'ENTREPOSAGE DE CET ÉQUIPEMENT À MOINS DE 4,4°C (40°F) FERA EN SORTE QUE L'HUILE HYDRAULIQUE DEVIENDRA ÉPAISSE. CECI POURRAIT CAUSER DES BRUITS INHABITUELS LORSQUE LE MOTEUR DE LA BASE FONCTIONNE. ON RECOMMANDE QUE L'ÉQUIPEMENT DEMEURE À UNE TEMPÉRATURE DE 15°C (60°F) OU PLUS DURANT AU MOINS 8 HEURES AVANT DE L'UTILISER.

2. INSTALLATION

2.1. Unpacking

2.1.1. Chair

2.1.1.1. Cut the shipping bands, open the top of the shipping carton, and remove all packing material and boxes that can be easily reached. Remove (4) nuts and remove both base clamping boards.

2.1.1.2. It is recommended that the skid be positioned as close as possible to the desired chair location.

2.1.1.3. Remove at least two small shipping blocks stapled to the top of the skid. The chair can now be slid and/or tipped from the skid onto the floor.

2.1.1.4. Do not lift the chair by the upper structure. However, the chair may be tipped or slid into position by pushing or pulling on the upper structure.

2.1.1.5. With the chair in position, remove all remaining paper pads, plastic, tape, strings, etc.

2.2. Assembly

2.2.1. Headrest

2.2.1.1. Remove the headrest from its carton, and mount it into position onto the chair back. Using the proper hex key wrench, tighten the cap screw to clamp the headrest securely into its mounting bracket.

2.2.2. Power Receptacle

2.2.2.1. Locate the footswitch assembly, chair control cable, and the power cord assembly. Refer to Figure 1 for receptacle location and attach all cables.

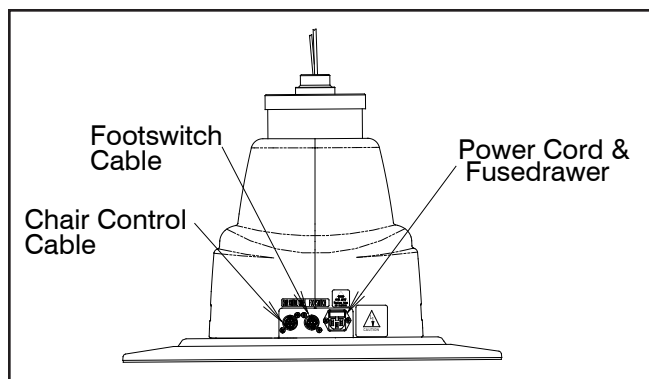

FIGURE 1
BASE

2.2.2.2. To disconnect power to Chair unplug power cord from Instrument Stand or from wall receptacle.



NOTE: Outlet wires are hot.



REMARQUE : Les fils de sortie sont chaud



NOTE: If this Chair is purchased in conjunction with a Reliance® Instrument Stand, the Chair Control Cable supplied will provide proper operation. Refer to the Instrument Stand Manual for connection to the Stand.



REMARQUE: Si cette chaise est achetée avec un support à instruments Reliance®, le câble de commande de la chaise fourni permettra un fonctionnement adéquat. Se référer au manuel du support d'instrument pour savoir comment faire la connexion au support

2.2.3. Setting Rotation Stop

2.2.3.1. When used in an ophthalmic or optometric environment, the rotation of the chair top is manufactured for a right-handed examination position (delivery system positioned on the patient's left). If you wish to position the floor unit for a left handed examination position, the rotation stop in the chair should be altered.

2.2.3.2. Separate the skirt hanging from the upholstered chair back connected to the upholstered seat by pulling upward on each end of the skirt until the Velcro fasteners are separated. Remove the screw located under the chair top and the front edge of the center of the chair. Lift upward on the seat and remove.

2.2.3.3. Standing in front of the chair locate the hole in the seat board positioned to the lower right of the center circle. Using a 1/2" socket, remove the bolt located in the circle, and install in the threaded hole located in the lower left of the center circle.

3. OPERATION



CAUTION- Caution should be taken to observe that there are no obstructions (instruments, trays, or tables) to impede the movement of the Chair.



PRÉCAUTION : On devrait faire attention pour s'assurer qu'il n'y a pas d'obstructions (instruments, plateaux, tables) empêchant le mouvement de la chaise.

Each time main power is applied to the chair, the circuit board inside the chair will respond with a one second beep. The beep indicates the electronics are functioning properly.

3.1. Stop Switch



3.1.1. Depressing the STOP switch on either side of the chair back will STOP ALL movement of the chair. The STOP switch is shaped like a stop sign, and may be either RED or ORANGE in color. It is located above the text "STOP". (Refer to Figure 2). The STOP switch is also used to program the chair. See Section 4 (page 13) for programming instructions.

3.2. Chair Lift

3.2.1. Raising & Lowering the Chair Lift with Membrane Switches



- The chair lift may be raised or lowered by Membrane Switches on either side of the chair back (Figure 2).
- To raise the chair lift from these switches, depress the triangular-shaped UP arrow located ABOVE the text "BASE". This is called the RAISE BASE switch.
- To lower the chair lift, depress the triangular-shaped DOWN arrow located BELOW the text "BASE". This is called the LOWER BASE switch.



NOTE: The RAISE and LOWER BASE switches on the Chair Back are programmable. By design, the motion of the Chair will STOP when either of these switches is released. If you want the motion of the Chair to CONTINUE after either of these switches is released, then see Section 4 for programming instructions.



REMARQUE : Les interrupteurs RAISE (LEVER) et LOWER (BAISSER) la base sur le dossier de la chaise sont programmables. Selon la conception initiale, le mouvement de la chaise S'ARRÊTE lorsque l'un ou l'autre de ces interrupteurs est relâché. Si vous désirez que le mouvement de la chaise CONTINUE, après que l'un ou l'autre de ces interrupteurs est relâché, consultez la section 4 pour connaître les instructions de programmation.

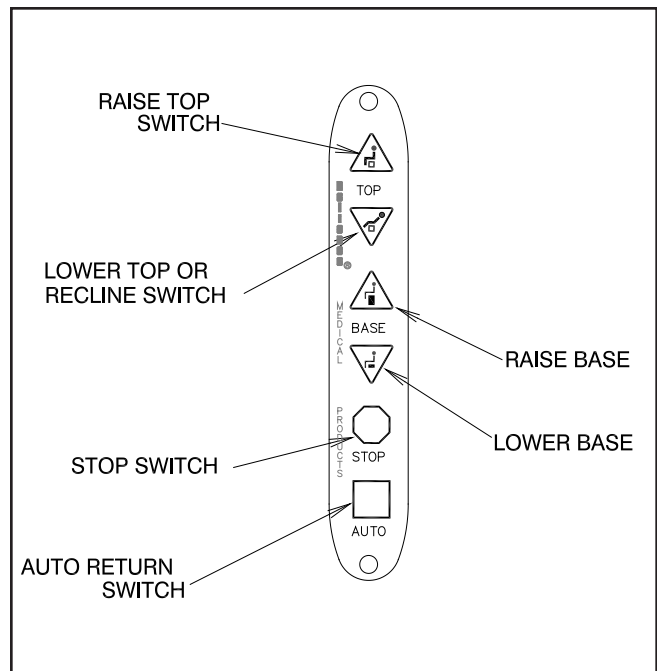

**FIGURE 2
MEMBRANE SWITCH**

3.2.2. Raising & Lowering the Chair Lift from the Footswitch



- For operation from the footswitch (Figure 3), depress the right side of the pedal to raise the chair lift.
- Depress the left side of the right-hand pedal to lower the chair lift.



NOTE: The RAISE and LOWER BASE switches on the Footswitch are programmable. By design, the motion of the Chair will STOP when either of these switches is released. If you want the motion of the Chair to CONTINUE after either of these switches is released, then see Section 4 for programming instructions.



REMARQUE : Les interrupteurs RAISE (LEVER) et LOWER (BAISSER) la base sur l'interrupteur au pied sont programmables. Selon la conception initiale, le mouvement de la chaise S'ARRÊTE lorsque l'un ou l'autre de ces interrupteurs est relâché. Si vous désirez que le mouvement de la chaise CONTINUE, après que l'un ou l'autre de ces interrupteurs est relâché, consultez la section 4 pour connaître les instructions de programmation.



NOTE: The RAISE and LOWER/RECLINE switches on the Chair Back are programmable. By design, the motion of the Chair will CONTINUE when either of these switches is released. If you want the motion of the Chair to STOP after either of these switches is released, then see Section 4 for programming instructions.



REMARQUE : Les interrupteurs RAISE (LEVER) et LOWER/RECLINE (BAISSER/INCLINER) sur le dossier de la chaise sont programmables. Selon la conception initiale, le mouvement de la chaise CONTINUE lorsque l'un ou l'autre de ces interrupteurs est relâché. Si vous désirez que le mouvement de la chaise S'ARRÊTE, après que l'un ou l'autre de ces interrupteurs est relâché, consultez la section 4 pour connaître les instructions de programmation.

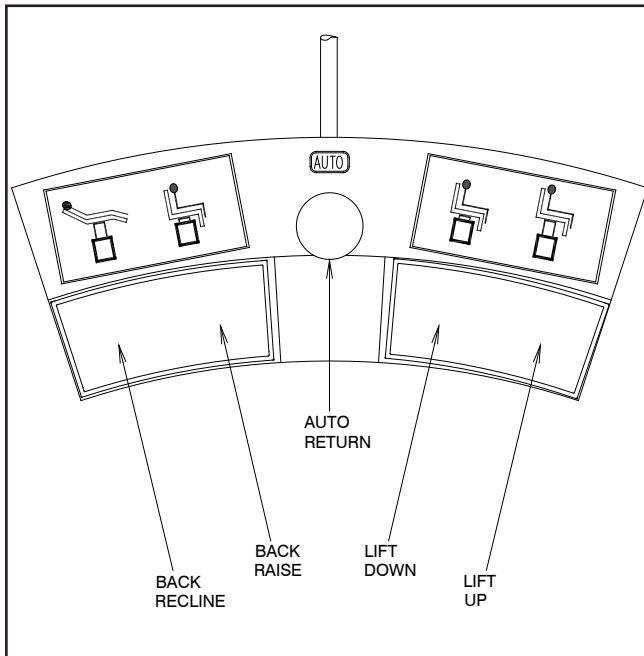

FIGURE 3
Footswitch Operation



CAUTION - ANY Chair movement that CONTINUES after the switch is released may be stopped by depressing the STOP switch or by depressing the same switch a second time.



PRÉCAUTION : TOUT mouvement de la chaise qui CONTINUE après que l'interrupteur est relâché peut être arrêté en appuyant sur l'interrupteur STOP (ARRÊT) ou en pressant le même interrupteur une seconde fois.

3.3. Chair Top

3.3.1. An electric motor supplies power for the movement of the chair top.

3.3.2. Raising & Reclining the Chair Top with Membrane Switches.

- The chair top may be raised or reclined by Membrane Switches on either side of the chair back (Figure 2).
- To lower, depress the triangle-shaped DOWN arrow located BELOW the "TOP". This is called the LOWER TOP or RECLINE switch.
- To raise the chair top from these switches, depress the triangle-shaped UP arrow located ABOVE the next "TOP". This is called the RAISE TOP switch.

3.3.3. Raising & Lowering the Chair Top From the Footswitch.



- For operation from the footswitch (Figure 3), depress the right side of the left-hand pedal to raise the chair top.
- Depress the left side of the left-hand pedal to lower/recline the chair top.



NOTE: The RAISE and LOWER/RECLINE switches on the Footswitch are programmable. By design, the motion of the Chair will STOP when either of these switches is released. If you want the motion of the Chair to CONTINUE after either of these switches is released, then see Section 4 for programming instructions.



REMARQUE : Les interrupteurs RAISE (LEVER) et LOWER (BAISSER/INCLINER) sur l'interrupteur au pied sont programmables. Selon la conception initiale, le mouvement de la chaise S'ARRÊTE lorsque l'un ou l'autre de ces interrupteurs est relâché. Si vous désirez que le mouvement de la chaise CONTINUE, après que l'un ou l'autre de ces interrupteurs est relâché, consultez la section 4 pour connaître les instructions de programmation.



CAUTION-This exam Chair is designed for use in a specific position called the Intended Use Position. Prior to reclining a patient, ensure the Chair Back is aligned with the Chair's power receptacle and that the Chair Swivel is locked. The safe working load is reduced if the Chair is swiveled away from this Intended Use Position, and may result in insufficient stability.



PRÉCAUTION : Cette chaise d'examen est conçue pour utilisation dans une position spécifique appelée la position d'utilisation prévue. Avant d'incliner un patient, assurez-vous que le dossier de la chaise est aligné avec le réceptacle d'alimentation de la chaise et que le pivot de la chaise est verrouillé. La charge de travail sécuritaire est réduite si la chaise est tournée hors de sa position d'utilisation prévue et cela pourrait causer une stabilité insuffisante



CAUTION: This exam Chair is designed for use with a specific maximum patient weight as a static (non-moving) load. Sudden weight shifts or impact loads can exceed the safe static load rating of the Chair, and may result in insufficient stability.



PRÉCAUTION : Cette chaise d'examen est conçue pour utilisation avec un poids de patient maximum spécifique comme charge statique (sans mouvement). Les déplacements de poids soudains ou les charges dynamiques peuvent excéder la norme de charge statique sécuritaire de la chaise, ce qui pourrait causer une stabilité insuffisante.



CAUTION: This exam Chair is designed for use with a patient properly positioned in the Chair. Prior to reclining the Chair, ensure that the patient is seated in the Chair and that the patient position does not move to an extreme position either toward the head of the Chair or toward the foot of the Chair, since this may result in insufficient stability.



PRÉCAUTION : Cette chaise d'examen est conçue pour utilisation avec un patient correctement positionné dans la chaise. Avant d'incliner la chaise, assurez-vous que le patient est assis dans la chaise et que la position du patient ne se déplace pas vers une position extrême soit vers la tête, soit vers le pied de la chaise, puisque cela pourrait causer une stabilité insuffisante.

3.4. Automatic Return

3.4.1. This feature is employed as a simple way for the operator to lower the chair lift and raise the chair back after completion of an examination or treatment. The automatic return system is activated by depressing the square switch located ABOVE the text "AUTO" on either side of the chair back. The chair lift, if raised, will then lower, and the chair back, if reclined, will rise to the upright position. These movements will CONTINUE after the switch is released until the chair lift is fully lowered and the chair back is fully upright. These movements may also be stopped by depressing the STOP switch or by depressing the AUTO switch a second time. The AUTO switch is square and is located in the same place on both Membrane Switches.

3.4.2. These instructions and operations also apply to any AUTO switch that is installed in a footswitch, console, or base cap.

3.5. Memory Feature

3.5.1. This system allows the operator to select a preferred examining position. The chair will automatically stop reclining when that point is reached.

3.5.2. Programming the Memory Feature

Step 1) Press the AUTO Switch. The chair will lower the chair base to its lowest position. It will also raise the chair back to its most upright position. Wait 20 seconds.

Step 2) Press and hold the RAISE TOP Switch. The chair back will NOT move since it is already upright. While maintaining pressure on the RAISE TOP switch, press the RECLINE switch. The chair will enter a programming mode and begin to recline and the switches will blink rapidly. At this point release the switches.

Step 3) Press the STOP Switch when the chair top arrives at the desired recline position. This completes the programming setup.

Step 4) To use the memory feature once it has been programmed, press the AUTO Switch. The LED's will blink and the chair will return to its full upright position. The LED's will stop blinking. Then press the RECLINE Switch which is programmed for memory mode. (Specify which RECLINE Switch will utilize this feature.) The switches will blink and the chair will recline on its own and stop at the programmed point.



NOTE: Memory switches on the right and left sides of the Chair Back work independently of each other. If the Memory Feature is activated on the left side, the right side will continue to recline the Chair all the way back with one touch. If you also want to activate the Memory Feature on the right side of the Chair, repeat Steps 1-4 on the right side of the Chair.



REMARQUE : Les interrupteurs à mémoire sur les côtés droit et gauche du dossier de la chaise fonctionnent indépendamment l'un de l'autre. Si la fonctionnalité de mémoire est activée du côté gauche, le côté droit continuera à incliner la chaise jusqu'au bout avec une seule touche. Si vous désirez aussi activer la fonctionnalité de mémoire du côté droit de la chaise, répétez les étapes 1 à 4 sur le côté droit de la chaise.



NOTE: The Memory Feature does not control the raise motion of the Chair Back.



REMARQUE : La fonctionnalité de mémoire ne commande pas le mouvement d'élévation du dossier de la chaise.

3.6. Revolving/Rotation

3.6.1. The chair upper structure may be revolved 350°, with a built-in stop to prevent continuous rotation. The lock for revolving is controlled by a hand lever with chrome plated knob located below the seat at the center and on either side. Push the lever down to release the lock and lift to apply the lock.

3.7. Arm Movement

3.7.1. The chair arms may be raised to provide better access to the patient or to permit entrance to or exit from the chair.

3.7.2. The movements of both arms are identical and completely independent of each other.

3.7.3. To raise an arm, push rearward on the middle joint of the arm support link while raising upward on the arm. A stop limits upward motion of the arm to a point parallel to the plane of the back. Lowering the arm automatically locks it in place against vertical motion in either direction.

3.8. Footrest

3.8.1. The footrest may be retracted by lifting near its outer edge. When fully retracted the footstep will stay in place.

3.8.2. Additional footpad is provided for use when patient is placed on abdomen.

3.9. Headrest

3.9.1. The No. 10 headrest is the standard headrest for the Model 710 Chair.



WARNING- IF THE NO. 18 HEADREST RECEIVES A IMPACT OR STRIKES AN OBJECT WITH FORCE CONTACT RELIANCE® TECH SERVICE IMMEDIATELY.



AVERTISSEMENT : SI L'APPUIE-TÊTE # 18 REÇOIT UN CHOC OU FRAPPE UN OBJET AVEC FORCE, CONTACTEZ IMMÉDIATEMENT LE SERVICE TECHNIQUE RELIANCE®.

3.9.2. Operation-No. 18, 22 Headrest

3.9.2.1. The No. 18, 22 headrest is designed so it can be operated with just one hand. To unlock, squeeze the clear plastic actuator into lock housing. This will allow both pivots of the articulating arm to rotate so the headrest can be moved to a new desired position. Once in the new position, release the actuator. Make sure the actuator expands to its original position fully exposing black dot on handle to insure a positive lock. The headrest pad is free to rotate at all times. (See Figure 4).

3.9.3. Adjustment-No. 18, 22 Headrest

3.9.3.1. There are three adjustments provided on the No. 18, 22 headrest. The first is the tension on the pad rotation. By tightening the two hex acorn nuts on the pad pivots with a 3/8" open end wrench, the tension will be increased. To adjust the drag on the pivots of the articulating arm, loosen the set screw in the center of the pivot (Figure 4, item 1) with a 3/32" hexagon key wrench. Next, tighten the pivot screw on the other side of the pivot, with a 1/8" hexagon key wrench. Now, retighten the set screw to retain the pivot screw at the new adjustment. Either pivot may be adjusted.

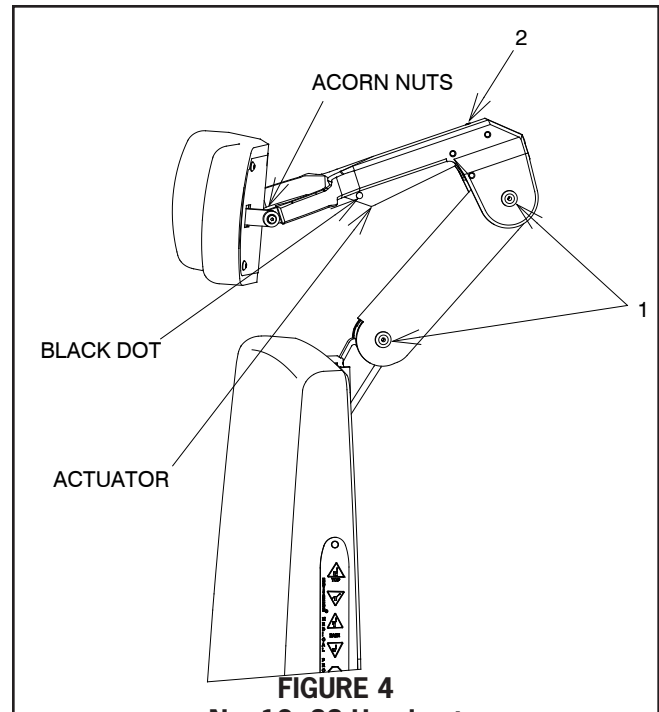

3.9.3.2. The third adjustment is for proper clearance of the block dot to indicate that the headrest is properly locked. If the dot does not fully clear the lock housing when the headrest is locked securely, turn the set screw located at the top of the lock housing (Figure 4, item 2) counterclockwise until the dot on the actuator is fully exposed.

3.9.4. Operation-No. 10, 30 Headrest

3.9.4.1. The No. 10 headrest has a fixed, rigid upholstered backboard which supports a sliding, center pillow section. For patient comfort simply move this pillow to a desired position.

3.9.4.2. The No. 30 headrest has a fixed, rigid upholstered backboard which supports a moveable, center Pillow Assembly. The Pillow Assembly is magnetically retained to the Upholstered Backboard, and may be re-positioned as required for Patient comfort. The Pillow is easily removed if it is not required.

3.9.5. Operation-No. 11, 21, 31 Headrest

3.9.5.1. A single handle on the rear of the No. 11, 21, 31 headrests controls the locking mechanism. To unlock, grasp the handle and turn counter-clockwise. Change the tilt of the headrest until it is in the desired position. To lock, turn the handle clockwise until snug. (See Figure 5, No. 11 Headrest shown)

3.9.6. Adjustment-No. 11, 21, 31 Headrest

3.9.6.1. The handle on the outermost knob can be adjusted to any preferred, locked position. Simply push in on the large screw while pulling out on the handle. Rotate as desired, and release. (See Figure 5, No. 11 Headrest shown)

3.9.6.2. The No. 21 headrest pillow assembly will slide to a preferred patient position. Simply slide pillow on the attached headrest strap to the desired position. (Not Shown)

3.9.6.3. The No. 31 headrest has an upholstered backboard which supports a moveable, center Pillow Assembly. The Pillow Assembly is magnetically retained to the Upholstered Backboard, and may be repositioned as required for Patient comfort. The Pillow is easily removed if it is not required.

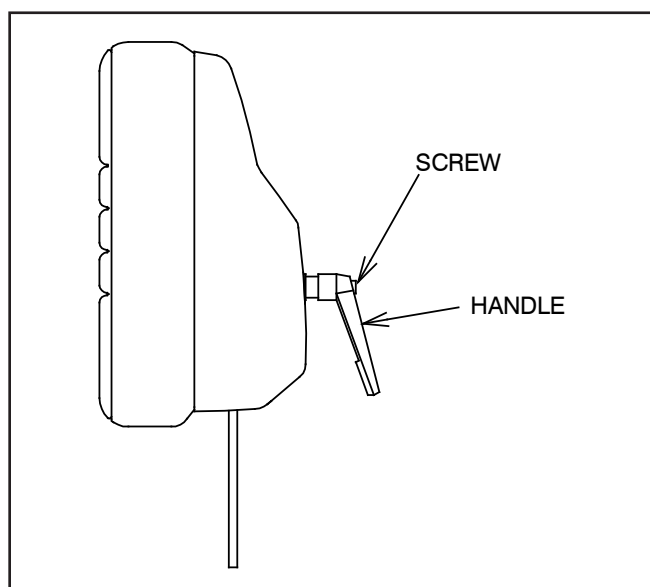

FIGURE 5
No. 11 Headrest

3.9.7. Operation-No. 20 Headrest

3.9.7.1. There are two lock handles on the No. 20 Headrest. Both handles unlock by turning counter-clockwise.

3.9.7.2. To change the tilt of the headrest unlock handle (Figure 6, item 1).

3.9.7.3. To change the height of the wrist support unlock handle (Figure 6, item 2).

3.9.7.4. When desired, the upper, curved wrist support bar (Figure 6, item 3) can be rotated up, out of the way. This also allows required clearance for a patient who is entering or leaving the chair.

3.9.8. Adjustment-No. 20 Headrest

3.9.8.1. The lever part of either lock handle can be relocated to any preferred, locking position. Simply push in on the large screw while pulling out on the handle, rotate the lever as desired, and release.

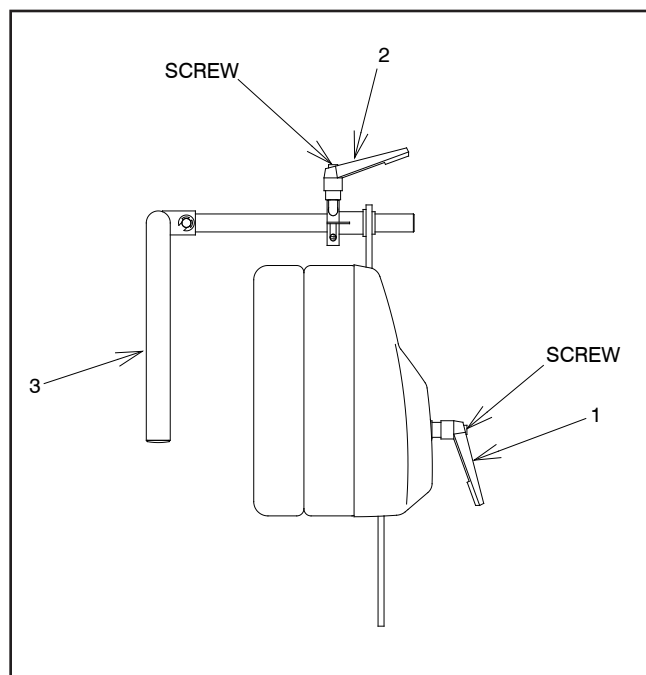

FIGURE 6
No. 20 Headrest

3.9.9. Operation-No. 27 Headrest

3.9.9.1 The No. 27 Headrest is designed to tilt and fold to a stowed location whenever it could interfere with a specific Examination or Procedure. Remaining attached to the chair, this Headrest is easily rotated and returned to its Standard Operating Position.

3.9.9.2. The Pillow Assembly is magnetically retained to the Upholstered Backboard, and may be re-positioned as required for Patient comfort. The Pillow is easily removed if it is not required.

3.9.9.3. To install the Headrest, lift up on the Release Lever (See Figure 7) and tilt the Headrest backward. Fold (Rotate) the Headrest down until screws are clearly visible. Place mounting plate into headrest bracket; tighten screws with a 1/4" Allen Wrench. Rotate Headrest in a straight up position, and then push forward to lock for normal operation.

3.9.9.4. To stow the Headrest, lift up on the Release Lever (See Figure 7) and tilt the Headrest backward. Fold (Rotate) the Headrest down (180°). Gravity and Friction will retain the Headrest in its stowed position, where it will not interfere with any movements of the Chair Top.

3.9.9.5. To return the Headrest to its Standard Operating Position, rotate straight up, then push forward to lock into position.

3.9.10. Adjustment-No. 27 Headrest

3.9.10.1 For proper operation, all adjustments have been made at the factory.

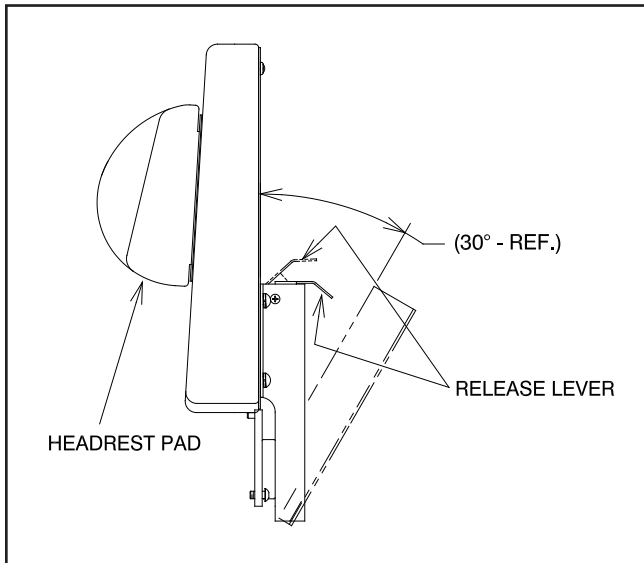

FIGURE 7
No. 27 Headrest

3.9.11. Operation C6 Headrest

3.9.11.1 A single handle on the rear of the C6 headrest controls the locking mechanism. To unlock, grasp the handle and turn counter-clockwise. Change the tilt of the headrest until it is in the desired position. To lock, turn the handle clockwise until snug. (See Figure 8)

3.9.12. C6 Headrest Adjustment

3.9.12.1. The handle on the outermost knob can be adjusted to any preferred, locked position. Simply push in on the large screw while pulling out on the handle. Rotate as desired, and release. (See Figure 8)

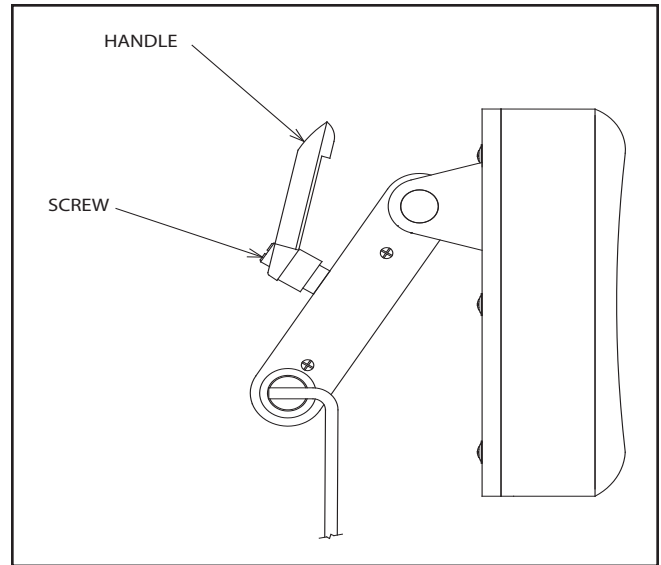

FIGURE 8
C6 Headrest

4. PROGRAMMING THE CHAIR

The items described in Section 4. are built-in features of the chair. Only those users who wish to utilize these features need to be concerned with this Section. The chair will operate as previously designed if these features are not used. The chair can be programmed in the same fashion from either switch located on the chair back.

4.1. Safety/Shutdown Feature

The chair has a built-in Safety/Shutdown feature. This feature causes the chair to shutdown or become inoperable. This feature prevents unauthorized use of the chair. (See Figure 2).

4.1.1 To ENTER Safety/Shutdown Mode

4.1.1.1 Depress and HOLD either STOP switch.

4.1.1.2 With the STOP switch depressed, depress the LOWER BASE switch on the same side of the chair back.

4.1.1.3 A two second beep will be heard to indicate the chair will NOT move if any additional switches are depressed.

4.1.1.4 The LED's on the Membrane Switches will blink every three seconds while in Safety/Shutdown Mode.

4.1.2 To EXIT Safety/Shutdown Mode, repeat the above sequence.

4.1.2.1 Depress and HOLD either STOP switch.

4.1.2.2 With the STOP switch depressed, depress the LOWER BASE switch on the same side of the chair back.

4.1.2.3 A two second beep will be heard to indicate the chair is functional, and movement of the chair WILL OCCUR when another switch is depressed.

4.1.2.4 The LED's will come back on when the chair becomes operational.

4.2. Individual Programming of the RAISE TOP, RECLINE TOP, RAISE BASE, and LOWER BASE switch located on the Chair Back or Footswitch. (See Figure 2 & 3).

4.2.1 These individual switches may be programmed to function in two ways. If the movement of the chair STOPS when the switch is released, this is called the MOMENTARY MODE of operation. If the movement of the chair continues after the switch is released, this is called the MAINTAINING MODE of operation. The factory designed setting for the RAISE TOP and RECLINE TOP switches located on the chair top is MAINTAINING MODE. The factory designed setting for the RAISE BASE and LOWER BASE switches located on the chair top is MOMENTARY MODE. If changed, the new settings will remain permanent as long as main power remains applied to the chair and will apply to the similar function on the other side.

4.2.2 To change these settings the chair must be placed in Setup Mode. Once in Setup Mode, depressing one of these switches will change its present setting from MOMENTARY to MAINTAINING or from MAINTAINING to MOMENTARY. Depressing a switch repeatedly will cause the setting to toggle between the two modes of operation.

4.2.3 To ENTER Setup Mode and change current setting.

4.2.3.1 Depress and HOLD either STOP switch.

4.2.3.2 With the STOP switch depressed, depress the AUTO switch on the same side of the chair back.

4.2.3.3 A one second beep will be heard to indicate you have ENTERED Setup Mode. The LED's will blink on and off while in Setup Mode.

4.2.3.4 Depress any of the following switches (including footswitch), one at a time, to toggle its current setting - RAISE TOP, RECLINE TOP, RAISE BASE, OR LOWER BASE. When the switch is depressed, a SHORT beep (0.25 seconds) will indicate the switch is now in MOMENTARY MODE of operation. A LONG beep (1.05 seconds) will indicate the switch is now in MAINTAINING MODE of operation.

4.2.3.5 When finished programming the chair, the chair MUST be taken out of Setup Mode.

4.2.4 To EXIT Setup Mode, repeat steps 1 & 2 above.

4.2.4.1 Depress and HOLD either STOP switch.

4.2.4.2 With the STOP switch depressed, depress the AUTO switch on the same side of the chair back.

4.2.4.3 A one second beep will be heard to indicate the chair has EXITED Setup Mode. The LED's will come back on.



NOTE: Depressing a switch causes the mode of operation to TOGGLE between MOMENTARY and MAINTAINING operation. If a mistake is made, depress the same switch again to return that switch to its previous mode of operation. If, at any time, the user becomes lost or confused during the programming procedure, the Chair can be reset to the factory settings by disconnecting and then reconnecting main power to the Chair. Once reset, the programming procedure can be repeated.



REMARQUE : Appuyer sur un interrupteur fait BASCULER le mode de fonctionnement entre MOMENTANÉ et MAINTENU. Si vous avez fait une erreur, appuyez de nouveau sur le même interrupteur pour le ramener à son mode de fonctionnement préalable. Si, en tout temps, l'utilisateur devient perdu ou confus durant la procédure de programmation, la chaise peut être réinitialisée aux réglages d'usine en déconnectant et en reconnectant l'alimentation principale à la chaise. Une fois réinitialisée, la procédure de programmation peut être répétée.

4.3. BEEP-ON-SWITCH Feature

4.3.1 The chair can be programmed to beep whenever a switch is depressed. This gives the user additional feedback on the operation of the chair. The factory design is to have NO BEEP occur when a switch is depressed. To change this setting the chair must be in Setup Mode. See Section 4.2.4. on how to ENTER Setup Mode. Once in Setup Mode,

4.3.2 Depress either AUTO switch on the chair back to toggle the BEEP-ON-SWITCH feature between ON and OFF.

4.3.3 A short beep (0.25 seconds) indicates NO BEEP will occur when a switch is depressed. A long beep (1.05 seconds) indicates a BEEP occur when a switch is depressed.

4.3.4 When finished programming the chair, the chair MUST be taken out of Setup Mode. See Section 4.2.4. on how to EXIT Setup Mode.

4.4. Auto Up/Retinal Feature

The Auto Up/Retinal Feature is a convenient feature for Retinal Specialists. When either recline switch is programmed to operate in this mode, depressing that switch will cause the chair lift to rise and the chair top to recline

4.4.1 To ENTER Auto Up/Retinal Mode.

4.4.1.1 Depress and HOLD either STOP switch.

4.4.1.2 With the STOP switch depressed, depress the LOWER TOP switch on the right side of the chair back to program that switch for Retinal Mode.

4.4.1.3 A one second beep will be heard to indicate that switch has ENTERED Auto Up/ Retinal Mode. When depressed, the RECLINE TOP switch on the right-hand side of the chair will now cause the chair lift to rise and the chair top to recline.

4.4.1.4 To program the RECLINE TOP switch on the left-hand side of the chair, use that switch and repeat the same steps as described above.



NOTE: This movement will continue after the LOWER TOP switch is released. To stop the chair movement, press the STOP switch, or depress the same LOWER TOP switch a second time.



REMARQUE : Ce mouvement continuera après que le PREMIER contact INFÉRIEUR soit relâché. Pour arrêter le mouvement de présidence, appuyez sur le contact "ARRÊT", ou diminuez le même PREMIER contact INFÉRIEUR une deuxième fois.

4.4.2 To EXIT Auto Up/Retinal Mode, repeat the above sequence.

4.4.2.1 Depress and HOLD either STOP switch.

4.4.2.2 With the STOP switch depressed, depress the LOWER TOP switch on the same side of the chair back.

4.4.2.3 A one second beep will be heard to indicate that switch has EXITED Auto Up/Retinal Mode.

4.5. Home Feature

4.5.1 The Home Feature allows the user to program the distance the chair lift will travel when starting from the fully lowered position. Activating this Feature causes the chair to move upward for a fixed amount of time. The actual height achieved by the chair will vary slightly from the programmed height, depending on the weight of the patient.

4.5.2 The Home Feature can be initiated by any of the RAISE BASE switches, located on the chair back, footswitch, or instrument stand. Each switch can be independently programmed for a specified height.

4.5.3 To PROGRAM the Home Mode Feature.

4.5.3.1 The chair lift must be fully lowered. To make sure the lift is all the way down, DEPRESS the AUTO switch and wait at least fifteen seconds.

4.5.3.2 The RAISE BASE switches that are to be programmed for Home Mode, must be in Momentary Mode.

4.5.3.3 DEPRESS and HOLD either STOP switch located on the chair back.

4.5.3.4 With the stop switch depressed, DEPRESS the RAISE BASE switch to be programmed. The chair lift will begin to rise and the LED's will blink. Release both switches.

4.5.3.5 When the chair rises to the desired height, DEPRESS either STOP switch to program that height into the chair.

4.5.3.6 Repeat steps 1 thru 5 to program any other RAISE BASE switch for Home Mode.

4.5.4 To UTILIZE the Home Mode Feature.

4.5.4.1 When the chair is all the way down, depressing a Raise Base Switch that has been programmed for Home Mode will cause the chair to raise to the programmed height.

4.5.4.2 If a RAISE BASE switch is programmed for Home Mode, but the chair lift is not all the way down, the Raise Base switch will function like a momentary switch.

4.5.4.3 If any RAISE BASE switch is programmed for Home Mode, the LED's will blink for 15 seconds after the AUTO DOWN switch is depressed. When the LED's stop blinking, the chair lift is all the way down.

4.5.5 To EXIT the Home Mode Feature.

4.5.5.1 If the Home Feature is no longer needed for any of the RAISE BASE switches, depress a STOP switch and the desired RAISE BASE switch at any time when the chair lift is not all the way down.



NOTE: The Home Feature and Memory Feature can only be operated with the Base down and the Back fully upright See Section 3.5.2 Step 4



REMARQUE : La fonctionnalité Accueil et la fonctionnalité Mémoire peuvent être utilisées seulement lorsque la base est en bas et que l'arrière est entièrement relevé. Consultez la Section 3.5.2 Étape 4.

5.0 LOCATING AND REPLACING FUSES

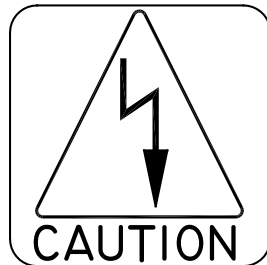
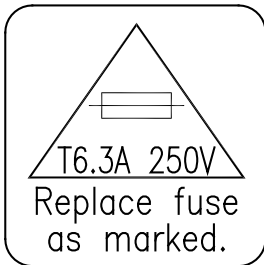

WARNING: DISCONNECT EQUIPMENT FROM MAIN INPUT POWER BEFORE PROCEEDING WITH ELECTRICAL INSPECTIONS OR MAINTENANCE.



AVERTISSEMENT : DÉCONNECTEZ L'ÉQUIPEMENT DE L'ALIMENTATION ÉLECTRIQUE PRINCIPALE AVANT DE PROCÉDER À DES INSPECTIONS ÉLECTRIQUES OU À DE L'ENTRETIEN.



CAUTION: Replace fuse(s) as marked. All fuses must be replaced with a fuse of the same size and rating. Refer to the Wire Diagrams at the end of this Manual.



PRÉCAUTION: Remplacez le(s) fusible(s) comme indiqué. Tous les fusibles doivent être remplacés par un fusible de la même dimension et de la même valeur. Se référer aux schémas de câblage à la fin de ce manuel.

The chair contains two fuses located inside the AC Input Module in the Base Assembly.

5.1. Fuse Replacement (AC Input Module)

5.1.1. Unplug the power cord from the AC power input module. Referring to Figure 8, locate tab. With a tool similar to a small common screwdriver placed under tab, pry fuse drawer out. Remove the drawer by pulling it out with your fingers.

5.1.2. To remove fuses from fuse drawer, tilt fuses in direction of arrows as shown in Figure 8. Examine the fuses, replace as necessary.

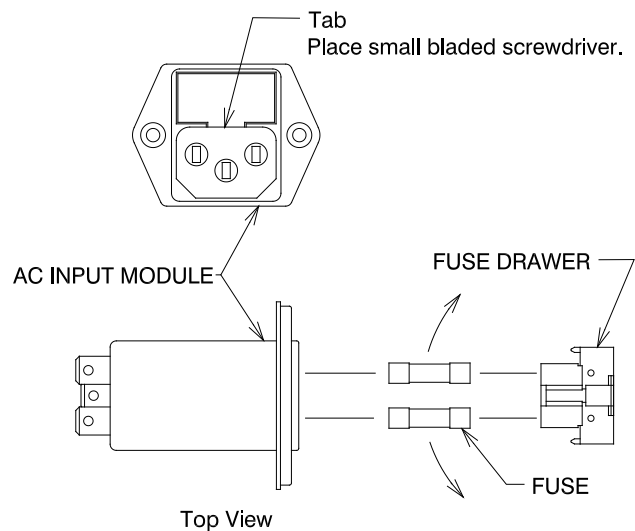

**FIGURE 9
AC INPUT MODULE**



CAUTION: To avoid a bind of the Fuse Drawer within the AC Input Module, never install the Fuse Drawer into the AC Input Module without fuses.



PRÉCAUTION : Pour éviter que le tiroir à fusible reste bloqué dans le module d'entrée CA, n'installez jamais le tiroir à fusible à l'intérieur du module d'entrée CA sans fusibles.

TROUBLESHOOTING GUIDE

PROBLEM	PROBLEM CAUSE	SOLUTION
CHAIR WILL NOT OPERATE.	<ol style="list-style-type: none"> 1) POWER CORD NOT PLUGGED IN. 2) NO AC POWER AT WALL RECEPTACLE. 3) BLOWN LINE FUSE. 	<ol style="list-style-type: none"> 1) CHECK ALL WIRING CONNECTIONS. 2) RESTORE OUTLET POWER. 3) REPLACE FUSE.
OUTLET POWER OK, BUT NO BEEP IS HEARD WHEN POWER IS APPLIED.	<ol style="list-style-type: none"> 1) BLOWN LINE FUSE. 2) LOOSE WIRING IN BASE. 3) OTHER. 	<ol style="list-style-type: none"> 1) REPLACE FUSE. 2) CHECK ALL WIRING CONNECTIONS. 3) CONTACT FACTORY
FOOTSWITCH FUNCTIONS NOT OPERATING.	<ol style="list-style-type: none"> 1) FOOTSWITCH CORD NOT CONNECTED. 	<ol style="list-style-type: none"> 1) CHECK ALL INTERNAL AND EXTERNAL FOOTSWITCH WIRING
BACKSWITCH FUNCTIONS NOT OPERATING.	<ol style="list-style-type: none"> 1) DAMAGED OR DISCONNECTED WIRES IN CHAIR BACK, UNDER CHAIR SEAT, OR IN CHAIR BASE 	<ol style="list-style-type: none"> 1) CHECK ALL WIRING CONNECTIONS.
CHAIR BASE WILL NOT STAY UP	<ol style="list-style-type: none"> 1) SOLENOID VALVE NOT CLOSED. (DIRT IN VALVE.) 2) CONSTANT POWER APPLIED TO SOLENOID. 3) OTHER 	<ol style="list-style-type: none"> 1) REPAIR OR REPLACE SOLENOID VALVE. 2) CHECK FOR SWITCHES STUCK "CLOSED" . 3) CONTACT FACTORY.
CHAIR BASE WILL NOT LOWER.	<ol style="list-style-type: none"> 1) NO POWER TO PUMP MOTOP ASS'Y. 2) SOLENOID COIL BURNED-OUT 3) OTHER 	<ol style="list-style-type: none"> 1) CHECK FOR VOLTAGE. 2) REPLACE SOLENOID COIL. 3) CONTACT FACTORY.
CHAIR BASE WILL NOT RAISE. PUMP MOTOR DOES NOT RUN.	<ol style="list-style-type: none"> 1) NO POWER TO PUMP MOTOR ASS'Y 2) UP-LIMIT SWITCH STUCK "OPEN". 3) PUMP MOTOR BURNED-OUT. 4) OTHER 	<ol style="list-style-type: none"> 1) CHECK FOR VOLTAGE. 2) RE-ADJUST OR REPLACE SWITCH. 3) REPLACE PUMP MOTOR ASS'Y. 4) CONTACT FACTORY.
CHAIR BASE WILL NOT RAISE. PUMP MOTOR RUNS.	<ol style="list-style-type: none"> 1) SOLENOID VALVE NOT CLOSED. (DIRT IN VALVE.) 2) CONSTANT POWER APPLIED TO SOLENOID. 3) OTHER. 	<ol style="list-style-type: none"> 1) REPAIR OR REPLACE SOLENOID VALVE. 2) CHECK FOR SWITCHES STUCK "CLOSED". 3) CONTACT FACTORY.
BASE "STUTTERS" DURING ASCENT.	<ol style="list-style-type: none"> 1) HYDRAULIC FLUID LEVEL IS LOW. 	<ol style="list-style-type: none"> 1) CONTACT DEALER OR FACTORY FOR INFORMATION ON ADDING OIL.
CHAIR BASE WILL NOT RAISE OR LOWER FROM FLOOR UNIT.	<ol style="list-style-type: none"> 1) CHAIR CONTROL CABLE NOT PLUGGED IN. 2) BLOWN FUSE IN CHAIR BASE. 	<ol style="list-style-type: none"> 1) CHECK CABLE CONNECTIONS AT STAND CHAIR 2) REPLACE FUSE.
CHAIR TOP "WOBBLES" ON CHAIR BASE	<ol style="list-style-type: none"> 1) LOCK NUT IS LOOSE. (UNDER SEAT BOARD.) 	<ol style="list-style-type: none"> 1) TIGHTEN LOCK NUT.
CHAIR TOP "BINDS-UP"	<ol style="list-style-type: none"> 1) CHAIR TOP MOTOR (NUT-TUBE) IS OUT OF ADJUSTMENT. 	<ol style="list-style-type: none"> 1) CONTACT DEALER OR FACTORY FOR ADJUSTMENT PROCEDURE.
MEMORY SYSTEM INOPERATIVE.	<ol style="list-style-type: none"> 1) NOT PROGRAMMED PROPERLY. 2) LOOSE CONNECTIONS UNDER CHAIR SEAT. 	<ol style="list-style-type: none"> 1) SEE SECTION 3.5.2 2) CHECK ALL WIRING CONNECTIONS

CLEANING AND MAINTENANCE

Cleaning the Upholstery

When cleaning upholstery, it is suggested that you use all recommended commercial cleaning agents in an inconspicuous spot to check for potential damage to the upholstery material before applying to the entire area to be cleaned.

Day to Day soil:

Remove ordinary dirt and smudges with a mild soap and warm water solution. Dry with a soft, lint-free cloth or towel. For more difficult stains, use of a stronger detergent is recommended; however, follow the detergent manufacturer's instructions closely.

Disinfecting Material:

In order to disinfect, use a 1:9 solution of bleach and water (1 part bleach to 9 parts water). Wipe surface with damp cloth then rinse with water immediately, using a damp cloth.

Special cleaning problems:

The following methods are recommended to clean stains on PreFixx-protected vinyl upholstery. Most stains will be removed when these cleaning agents are used in the following order.

Type 1 Cleaners: Nonabrasive household cleaners to be used with water and a soft cloth.

- Formula 409~ All-Purpose Spray Cleaner
- Fantastik® Spray Cleaner
- Other similar household cleaners and bleaches

Type 2 Cleaners: Solvent-type cleaner to be liberally applied with a soft cloth. Dry area with another cloth, rinse with clean water and dry.

- Rubbing alcohol (isopropyl alcohol)
- Lighter fluid (naptha)

Type 3 Cleaners: Strong, active solvent cleaners such as nail polish remover (acetone/water) to be applied with a soft cloth. Stain should be removed with less than six (6) rubs; if stain persists after six rubs, contact manufacturer. Dry area with another cloth, rinse with clean water and dry.



CAUTION: These solvents are highly flammable. Exercise proper care in cleaning and notify personnel in the area of any dangers. Wear rubber gloves during all cleaning activity. Use caution in cleaning around buttons, stitching and wooden or other decorative trim, since these solvents could seriously damage such areas.



PRÉCAUTION : Ces solvants sont extrêmement inflammables. Faites très attention lors du nettoyage et avisez le personnel dans la zone de tout danger. Portez des gants de caoutchouc durant toute activité de nettoyage. Faites attention en nettoyant autour des boutons, des coutures et autres finitions de bois ou décoratives, puisque ces solvants pourraient endommager sérieusement ces endroits.

Cleaning Painted Surfaces

The painted metal surfaces are covered in durable, powder-coated paint which is resistant to scratching and scuffing. It may be cleaned with a clean cloth dampened with mild, soapy water or equivalent household product that uses spray application.

Recommended Infection Control Products

The disinfectant/cleaner products that we have tested and recommend for our upholstery, painted items and plastic covers are as follows.

- Cavicide® Hospital Disinfectant
- Precise® Hospital Foam Cleaner Disinfectant



CAUTION : Follow manufacturer's directions for concentration and application of disinfecting cleaner. Avoid prolonged application of any disinfectant/cleaner products, because they may cause staining or discoloration of material.



PRÉCAUTION : Suivez les instructions du fabricant pour la concentration et l'application de nettoyeurs désinfectants. Évitez une application prolongée de tout produit désinfectant/nettoyant, parce que ceux-ci pourraient causer des taches ou une décoloration du matér

PARTS LIST
RELIANCE® MODEL 710
EXAMINATION AND TREATMENT CHAIR

Note: When ordering parts, please:

1. Advise dealer or factory of model and serial number of unit. These numbers are on the plate that is located at rear, near bottom, of chair back.
2. Specify color of painted parts. Painted parts have an asterisk(*) behind the part description.

REMARQUE : Lorsque vous commandez des pièces, veuillez :

1. Informez le distributeur ou l'usine du modèle et du numéro de série de l'ensemble. Ces numéros sont de la plaque qui est située à l'arrière, près du bas, de l'arrière, présidence.
2. Spécifier la couleur des pièces peintes. Les pièces peintes ont un astérisque (*) derrière la description de pièce.

Should your Exam Chair not perform properly, or if replacement parts are needed, contact the Reliance® Distributor, where you purchased this product or contact the Technical Service Department, Reliance® Medical Products, Inc., 3535 Kings Mills Road, Mason, Ohio 45040-2303, or call (800) 735-0358.

**FIGURE 10
710 CHAIR ASSEMBLY (DESIGNER)**

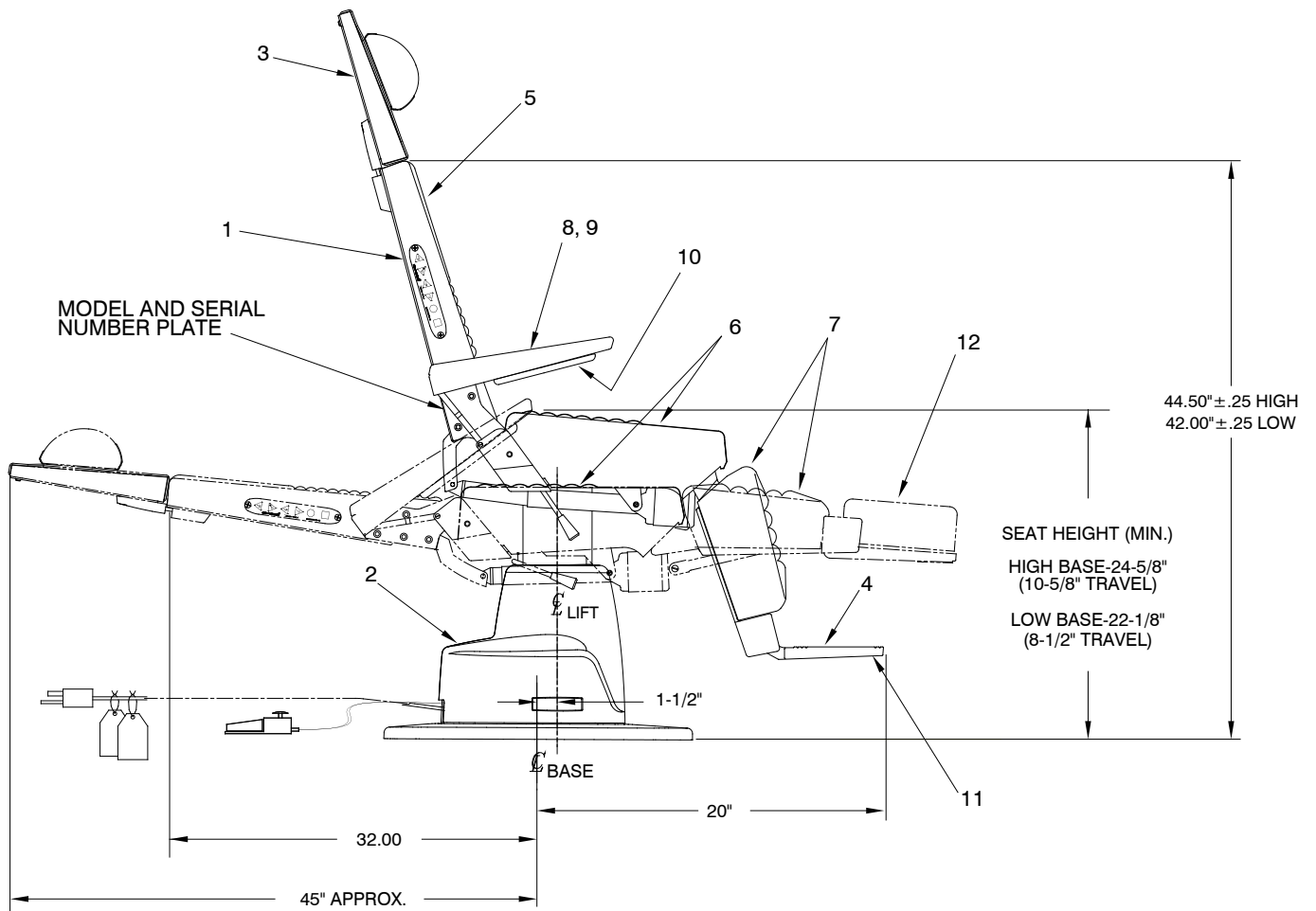

ITEM	PART NO.	DESCRIPTION	ITEM	PART NO.	DESCRIPTION
1		Chair Top Assembly* (See Figure 12)	7	1479473	Upholstered Apron Assembly**
2		Base Assembly* (See Figure 13)	8	1528273	Upholstered Arm Assembly-Right**
3		Headrest Assemblies (See Figures 15 thru 23)	9	1528373	Upholstered Arm Assembly-Left**
4	1760403	Footstep*	10	0667873	Upholstered Arm Pad Assembly**
5	1526873	Upholstered Back Assembly**	11	1765073	Scuff Pad**
6	1527373	Upholstered Seat Assembly**	12	1527773	Upholstered-Foot Cushion**

** Please specify upholstery color when ordering.
To order complete Upholstery Set use P/N.

*Please specify paint color when ordering.

1964273 Upholstery Set With No. 10 Headrest Pad - 710
2077973 Upholstery Set Without Headrest Pad-710

**FIGURE 11
710 CHAIR ASSEMBLY (PREMIERE)**

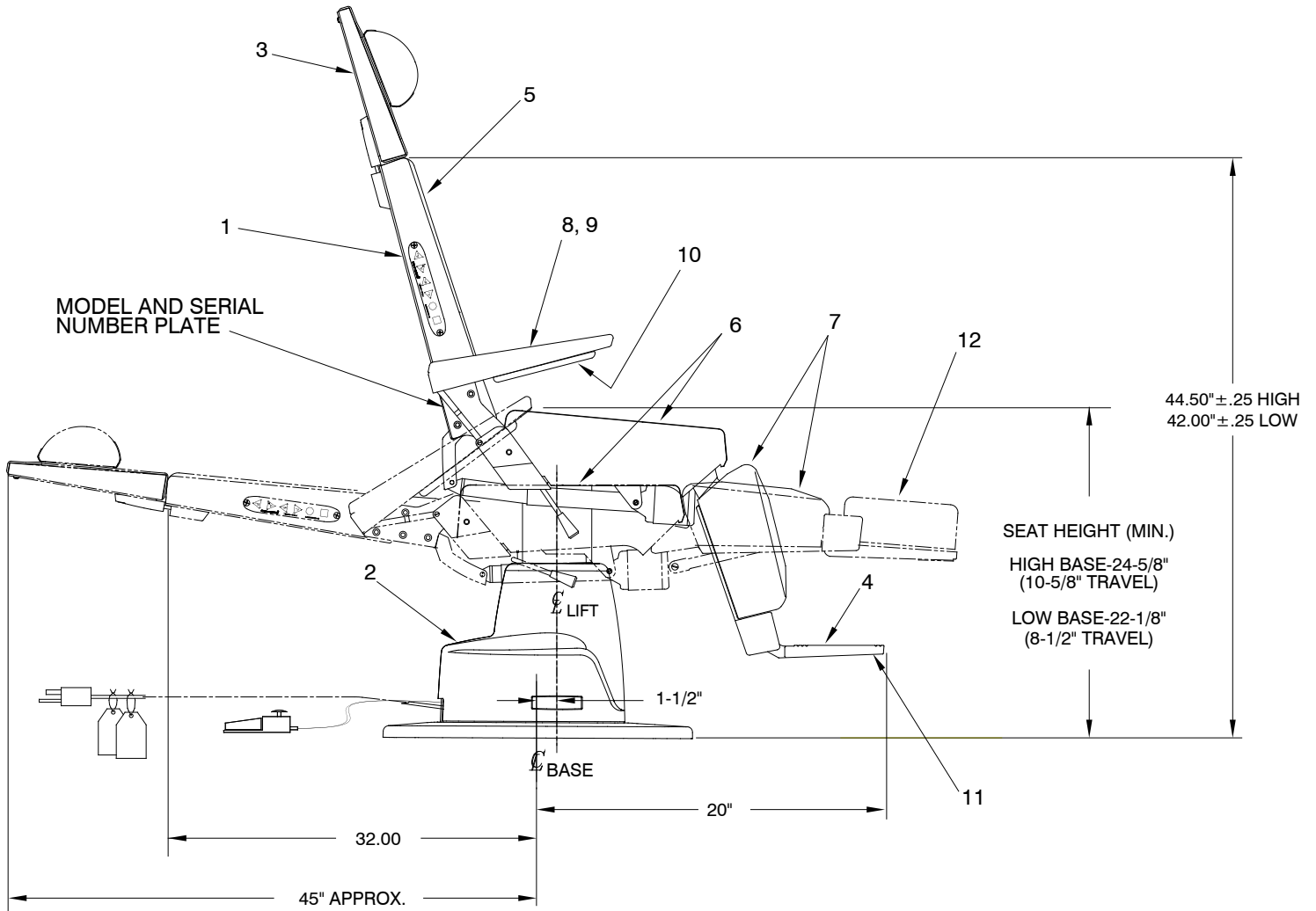

ITEM	PART NO.	DESCRIPTION	ITEM	PART NO.	DESCRIPTION
1		Chair Top Assembly* (See Figure 12)	7	3136473	Upholstered Apron Assembly (Premiere)**
2		Base Assembly* (See Figure 13)	8	3137173	Upholstered Arm Assembly-Right (Premiere)**
3		Headrest Assemblies (See Figures 15 thru 23)	9	3137273	Upholstered Arm Assembly-Left (Premiere)**
4	1760403	Footstep*	10	3137573	Upholstered Arm Pad Assembly (Premiere)**
5	3134973	Upholstered Back Assembly (Premiere)**	11	1765073	Scuff Pad**
6	3135073	Upholstered Seat Assembly (Premiere)**	12	1527773	Upholstered-Foot Cushion**

** Please specify upholstery color when ordering.
To order complete Upholstery Set use P/N.

*Please specify paint color when ordering.

3138673 Upholstery Set - with No. 10 Headrest Pad - 710

ITEM	PART NO.	DESCRIPTION	ITEM	PART NO.	DESCRIPTION
1	1546699	Hinge Cable Assembly	23	1643899	6 Circuit Plug
2	0708499	H.H.C.S. 3/8-16 x 1 1/4	24	1422492	Apron Board Assembly
3	0728299	1/4 Split Lock Washer	25	0722899	S.S.H.S. 1/4-20 x 3/8
4	0713199	R.H.M.S. 1/4-20 x .75	26	1760403	Footrest*
5	0715699	F.H.M.S. 3/8-16 x 1	27	0609699	Fiber Washer
6	0824399	T.H.M.S 8-32 x 3/8	28	0603585	Connecting Rod
7	1639692	Back Board Assembly	29	1478299	1/4 x 7/8 Drivlok Pin
8	0606199	3/8 Counter Sink Lockwasher	30	0614299	Footstep Pin Assembly
9	0603172	Side Plate Assembly - Right*	31	0606099	9/32 Dia Steel Ball
10	0603272	Side Plate Assembly - Left*	32	0605999	Spring
11	0396299	Spring Washer	33	0609372	Hanger Assembly - Right*
12	0725999	S.H.S.S. 1/4-20 x 3/4	34	0609472	Hanger Assembly - Left*
13	0761899	3/16 x 1 Roll Pin	35	0605299	Lock Handle Assembly - Right
14	0556285	Armrest Cover	36	0605399	Lock Handle Assembly - Left
	1528185	Armrest Cover	37	0569499	Roll Pin 3/16 x 3/4
15	0136703	Headrest Bracket*	38	0604092	Hanger Bracket Assembly - Right
16	0126303	Footstep Crank*	39	0604192	Hanger Bracket Assembly - Left
17	1529103	Back Cover - With ENT*	40	0762899	1/4 x 1 Drivlok Pin
	1528003	Back Cover - Without ENT*	41	1842692	Armrest Link Assembly - Right
18	0605499	Lock Shaft	42	1842792	Armrest Link Assembly - Left
19	0411199	Fiber Washer	43	0122203	Armrest Bracket - Right*
20	0603803	Back Hinge Assembly - Right*	44	0122303	Armrest Bracket - Left*
21	0603903	Back Hinge Assembly - Left*	45	0563299	Linkage Pin
22	0732699	1/2 Retaining Ring	46	1548099	Membrane Switch Assembly

For Items 47 thru 81 see page 25.

*Please specify paint color when ordering.

ITEM	PART NO.	DESCRIPTION	ITEM	PART NO.	DESCRIPTION
47	1546299	Ribbon Cable	64	0606399	8-32 Hinge Bracket Pin
48	0387303	Plug Button*	65	0603685	Apron Link
49	0603399	Truarc Ring	66	0125372	Back Bracket - Right*
50	0126485	Apron Bracket	67	0125472	Back Bracket - Left*
51	1660899	6 Circuit Cap	68	1108695	Back Angle Bracket
52	0643599	Lock Plug	69	0610472	Nut Tube Assembly*
53	0722899	S.H.S.S. 1/4-20 x 3/8	70	0569699	O.H.W.S. #6 x 3/4 Phil
54	0561799	Locking Cam	71	0808699	F.H.C.S. 1/4-20 x 1 Sck't
55	0604599	3/8-16 Mounting Screw	72	1111399	F.H.C.S. 1/4-20 x 3/4 Sck't
56	1421892	Seat Board Assembly	73	0611899	F.H.M.S. 1/4-20 x 1 3/4 Phil
57	0788699	H.S.C.S 1/4-20 x 1	74	0729999	1/4 Washer
58	0732599	Truarc Ring	75	0703699	1/4-20 Keps Hex Nut
59	0508699	Nylon Washer	76	0789199	R.H.M.S. #10-24 x 3/8
60	0125185	Seat Support	77	0706199	R.H.M.S. 1/4-20 x 1.15 Sck't
61	0708599	H.H.C.S. 3/8-16 x 1 1/2	78	0713599	F.H.M.S. 1/4-20 x 1.25 Phil
62	0728499	3/8 Lock Washer	79	0729199	1/4 Lock Washer
63	1660092	Actuator Assembly - 120V	80	2077192	Rod & Link Assembly
	1660192	Actuator Assembly - 230V	81	0729599	.375 Washer

For Items 1 thru 46 see page 24.

*Please specify paint color when ordering.

**FIGURE 13
CHAIR BASE ASSEMBLY**

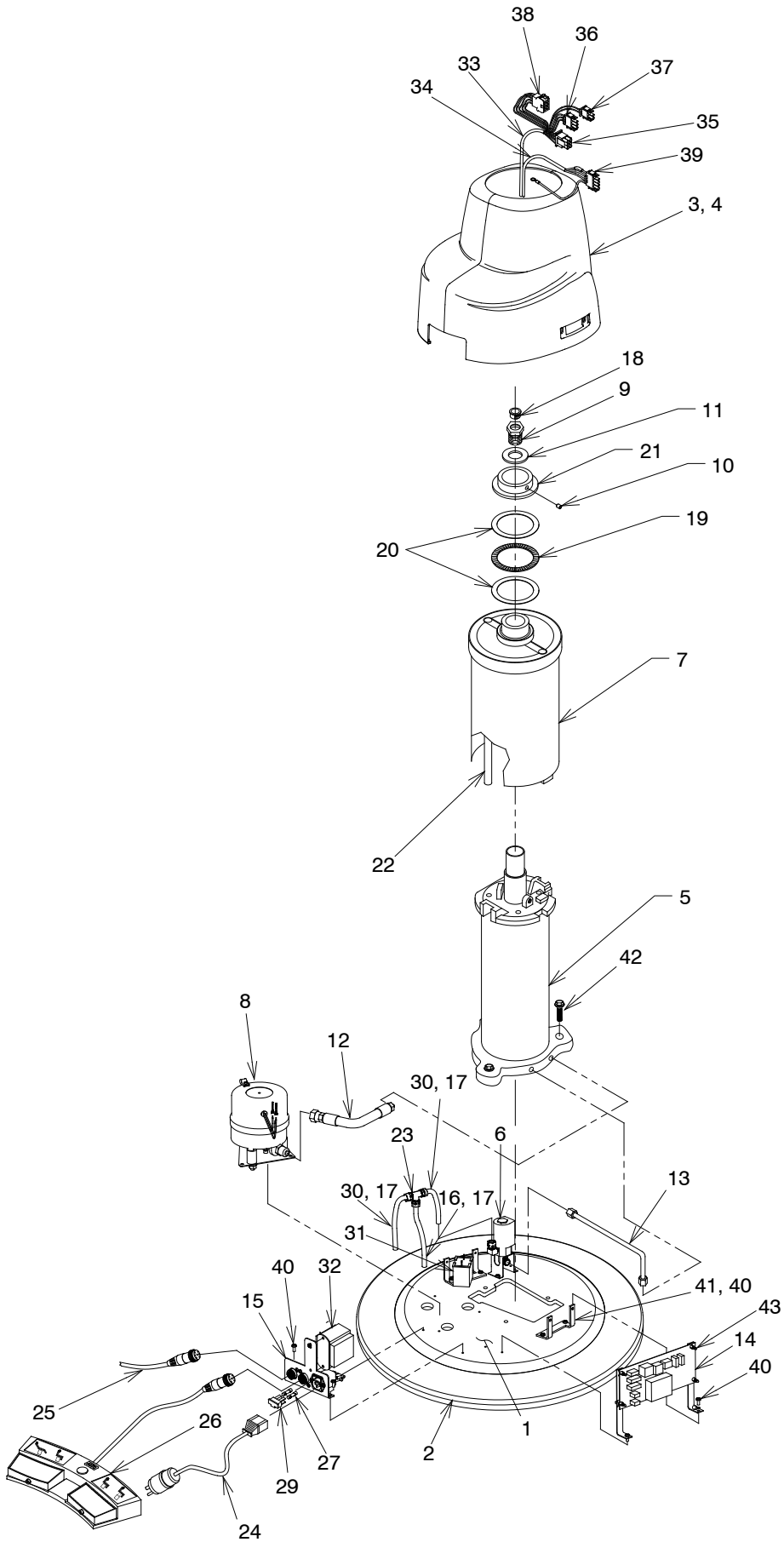

ITEM	PART NO.	DESCRIPTION	ITEM	PART NO.	DESCRIPTION
1	2080303	Base	23	1127599	Union Tee
2	1738380	Base Ring Assembly		1659299	Power Cord Assembly 120V (US)
3	2065199	Base Housing - Low - RH	24	2832299	Power Cord Assembly 230V (US)
	2065399	Base Housing - High - RH		2363100	Power Cord Assembly INT'L Options
4	2065299	Base Housing - Low - LH		25	1550599
	2065499	Base Housing - High - LH	26	1608192	Footswitch Assembly
5		Lift Assembly (See Figure 10)	27	1634299	Fuse, 6.3 A / 250V-120V
6	1707792	Solenoid Valve Assembly-120V		1634999	Fuse, 4 A / 250V-230V
		1707892	Solenoid Valve Assembly-230V	28	1976799
7	1702892	Keyshield Assembly-Low*	29		Fusedrawer, 2 Pole (In Item 28)
	1702992	Keyshield Assembly-High*	30	0458999	Tubing-5 in
8	2720092	Pump/Motor Assembly-120V	31	1597299	Capacitor, Starting-120V
	2720192	Pump/Motor Assembly-230V		2002199	Capacitor, Starting-230V
9	1547899	Piston Rod Bolt	32	1993592	Ent Transformer Assembly - 120V
10	1525899	Set Screw-#10-24 x 1/4		1994392	Ent Transformer Assembly - 230V
11	0607299	Washer	33	2720399	Base Cable Grey
12	2721092	Hose Assembly	34	2720292	Base Cable Black
13	1596292	Pressure Tube Assembly	35	1643899	6 Circuit Plug
14	2025199	P.C. Board Assembly	36	1643699	3 Circuit Plug
15	2720892	AC Input Assembly	37	1660499	2 Circuit Plug
16	0458999	Tubing-5-1/2 in	38	1660899	6 Circuit Cap
17	1081999	Tubing Insert	39	1663892	Ground Wire Assembly- Actuator
18	1547999	Snap Bushing	40	1720399	PH Phil w/Lock Washer-#10-24 x 1/2
19	0559999	Thrust Bearing	41	2081099	Housing Mount Bracket
20	0560099	Thrust Washer	42	0708599	HHCS 3/8-16 x 1.5
21	0123885	Lock Nut	43	1569999	Circuit Board Support
22	1548195	Wiring Tube-High			
	1548395	Wiring Tube-Low			

To order complete Base Assembly use P/N's.

- 2713292 Chair Base Assembly - Low - 120V*
- 2713392 Chair Base Assembly - High - 120V*
- 2713492 Chair Base Assembly - Low - 220-240V*
- 2713592 Chair Base Assembly - High - 220-240V*

*Please specify paint color when ordering.

FIGURE 14
LIFT ASSEMBLY

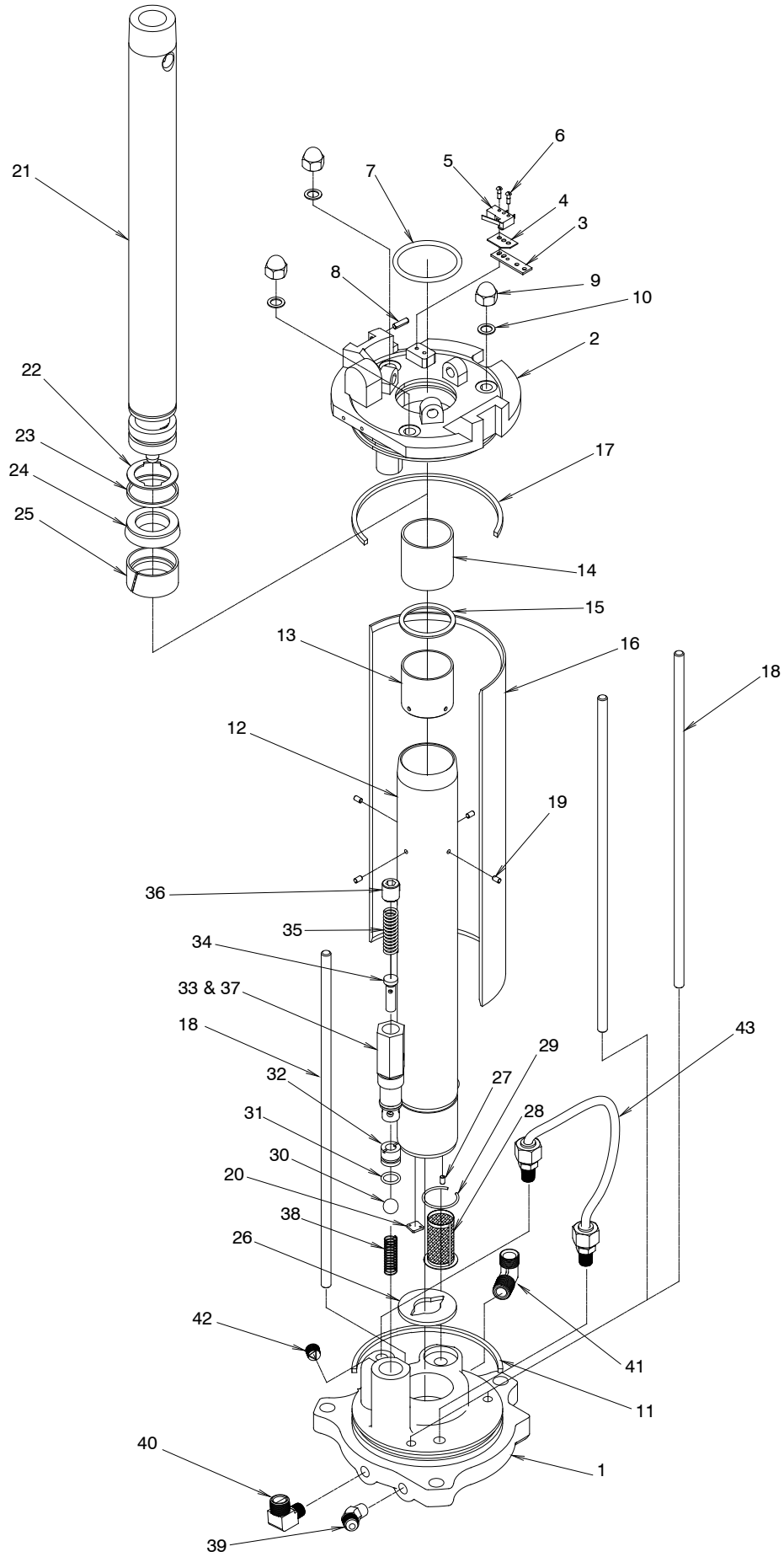

ITEM	PART NO.	DESCRIPTION	ITEM	PART NO.	DESCRIPTION
1	1012795	Lift Base	22	0733299	Retaining Ring
2	1019095	Lift Top	23	0512599	Backup Ring
3	0439979	Switch Plate	24	0730899	U - Pack
4	0929699	Insulator	25	0512499	Piston Ring
5	1011399	Switch	26	0353199	Cylinder Gasket
6	0727599	Drive Screw	27	0569299	Pin - Roll
7	0731499	"O" Ring	28	0466399	Filter Screen
8	1454699	Pin	29	0446099	Snap Ring
9	0485199	Nut - Acorn 5/16	30	0741799	Valve Ball
10	0365799	Gasket - Tie Rod	31	0731199	"O" Ring
11	0432599	Base Column Seal	32	0441999	Valve Seat
12	0903292	Cylinder Assembly - High	33	1012499	Valve Housing
	0526792	Cylinder Assembly - Low	34	0363299	Relief Valve Plunger
13		Spacer - Cylinder (in Item 12)	35	0784699	Relief Valve Spring
14		Bushing (in Item 12)	36	1012399	Set Screw
15		Ring - Quad (in Item 12)	37	0731299	"O" Ring
16	0902285	Base Column - High	38	0442499	Valve Spring
	0563885	Base Column - Low	39	2720799	Elbow - 45°
17	0432599	Base Column Seal	40	1081899	Elbow - 90°
18	0901999	Tie Rod - High	41	0447199	Elbow - 90°
	0563699	Tie Rod - Low	42	0303699	Plug - Pipe 1/8-27 Sckt Head
19		Pin - Roll (in Item 12)	43	1060392	Tubing Assembly
20	0422899	Disc - Valve			
21	1183592	Piston Rod - High			
	1183692	Piston Rod - Low			

To order complete Lift Assembly use P/N's.

2721192 Lift Assembly - Low

2721292 Lift Assembly - High

FIGURE 15
18 & # 22 HEADREST ASSEMBLY

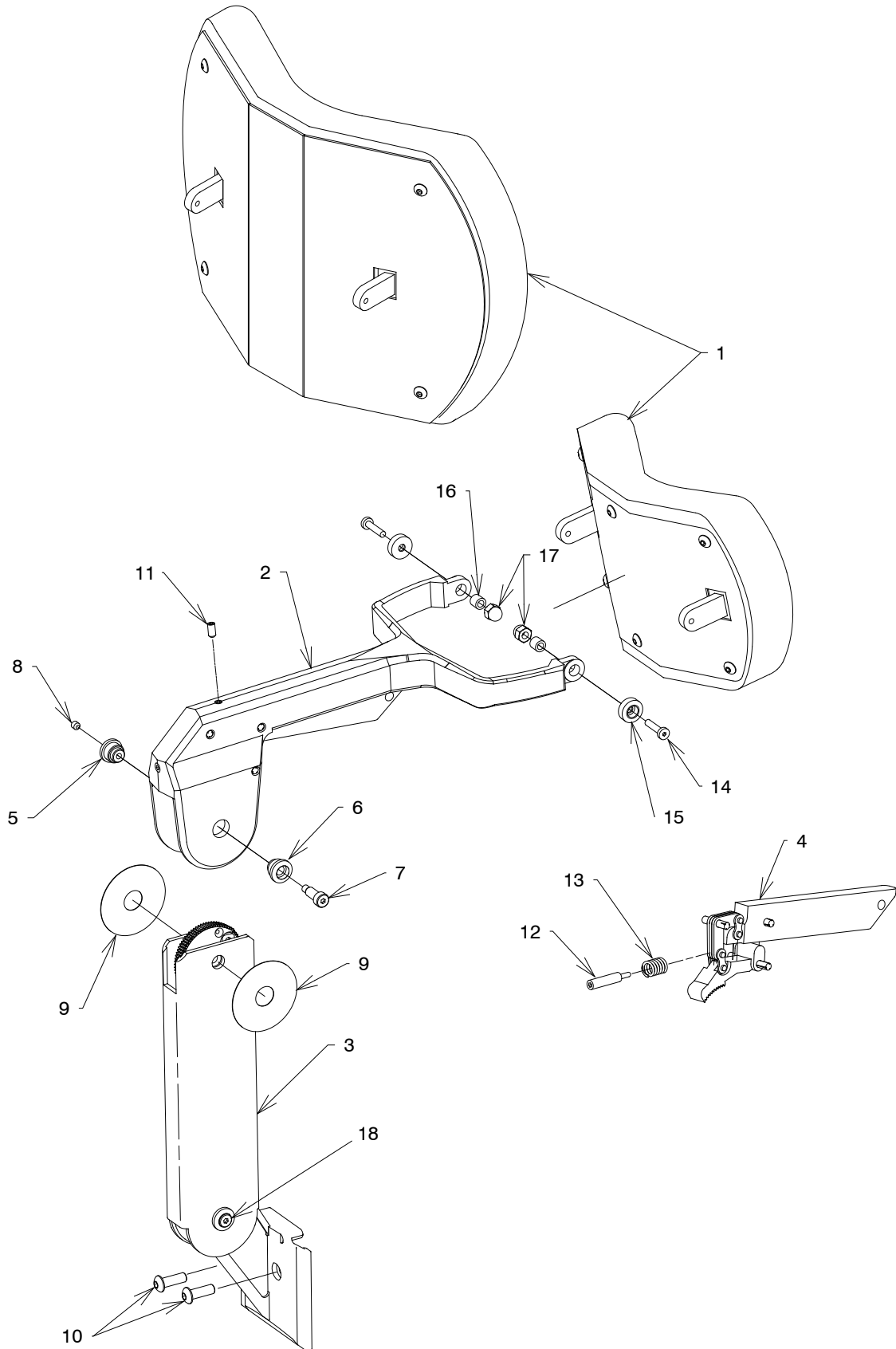

ITEM	PART NO.	DESCRIPTION
1	0475673	Pad Assembly - No. 18*
	1680073	Pad Assembly - No. 22*
2	1460492	Yoke Assembly*
3	1460592	Gear & Bracket Assembly*
4	1470692	Actuator & Lock Gear Assembly
5	1425299	Pivot Cap, Right
6	1425399	Pivot Cap, Left
7	0307599	Screw, Shoulder 1/4 x 1
8	0726099	S.H.S.S. #10-24 x 3/16
9	1424999	Washer, 2" OD
10	1454799	B.H.C.S. 1/4-28 x 1/2
11	1456399	S.H.S.S. #10-24 x 3/8
12	1427099	Spring Plunger
13	1538899	Spring
14	1454999	L.H.C.S. #10-24 x 3/4 - Socket
15	1434799	Pivot Cap, Pad
16	0467195	Bushing .188 I.D x .312 O.D.
17	1456199	Nut, Acorn 1/4-20 Low Crown
18	1425699	Screw, Shoulder .25 x .50

To order complete Headrest Assembly use P/N.
144080 #18 Headrest Assembly*
144070 #22 Headrest Assembly*

*Please specify paint color when ordering.
** Please specify upholstery color when ordering.

To order complete Screw Assembly use P/N.
2721692 Middle Joint Screw Assembly
Includes: Item's 5, 6, 7 & 8.

2721792 Bottom Joint Screw Assembly
Includes: Item's 5, 6, 8 & 18

FIGURE 16
10 HEADREST ASSEMBLY

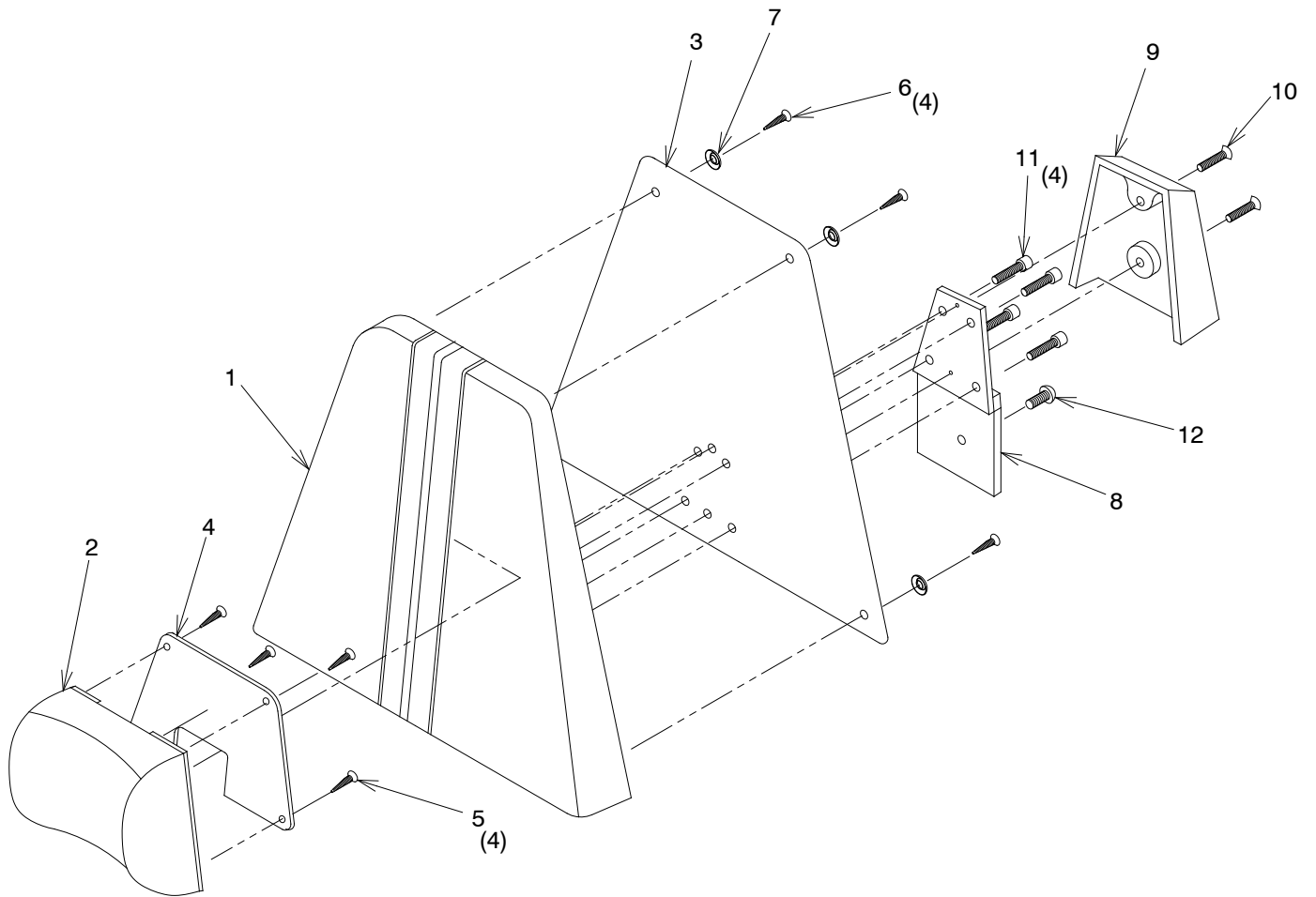

ITEM	PART NO.	DESCRIPTION
1	0665073	Uph # 10 Board Assembly**
2	0574173	Pillow Assembly - #10**
3	0567903	High Back Cover*
4	0568003	Pillow Back Cover*
5	0845199	F.H.W.S. #6 x .50 - Phil
6	0569699	O.H.W.S. #6 x 3/4
7	0569799	#6 Finishing Washer
8	0557499	Mounting Plate Assembly
9	0123203	Bracket Cover*
10	0808699	F.H.C.S 1/4-20 x 1.00 - Socket
11	0788699	S.H.C.S. 1/4-20 x 1.00
12	1454799	B.H.C.S., 1/4-28 x 1/2

To order complete Headrest Assembly use P/N.

665200 #10 Headrest Assembly*

*Please specify paint color when ordering.

** Please specify upholstery color when ordering.

FIGURE 17
11 HEADREST ASSEMBLY

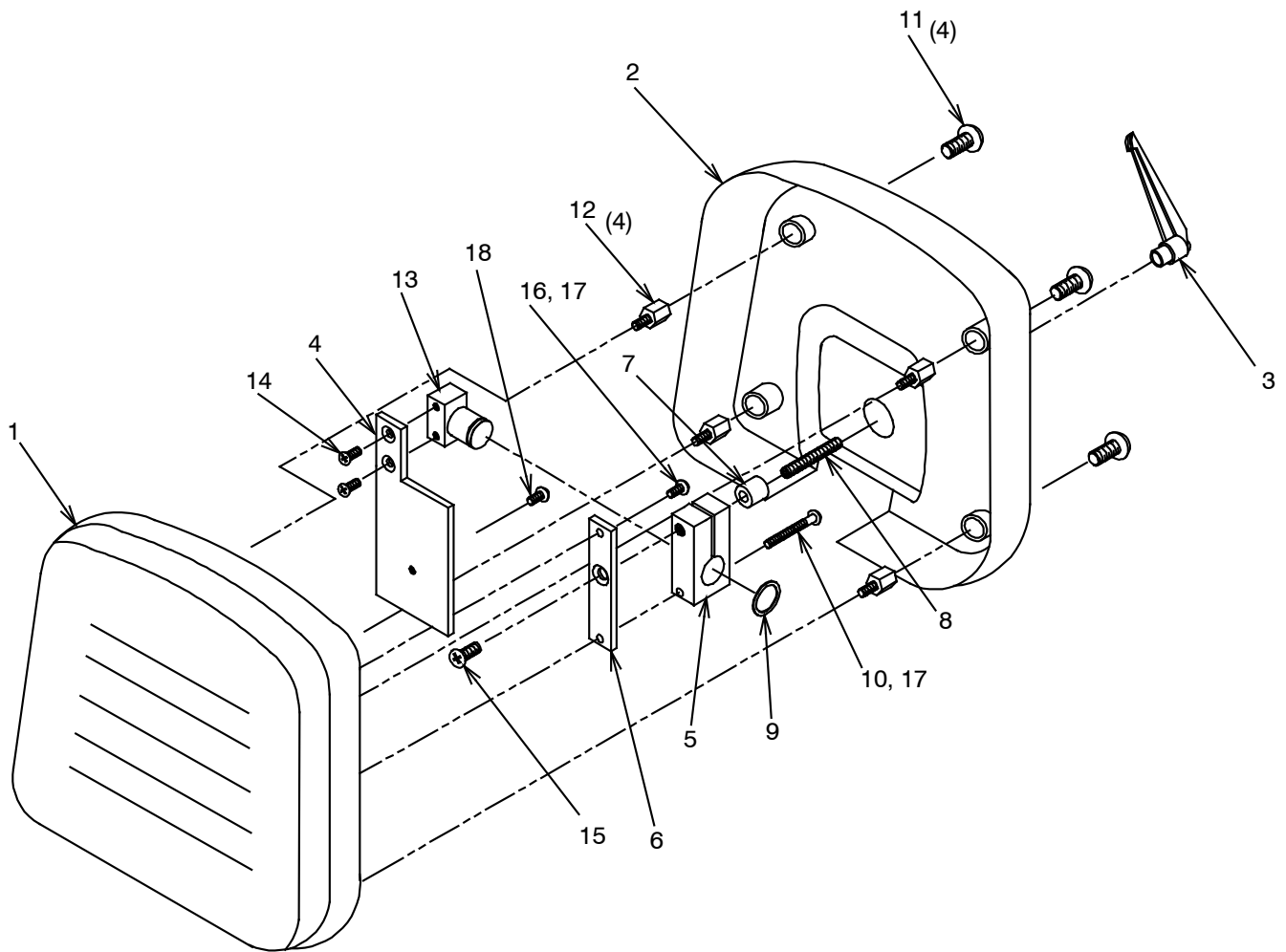

ITEM	PART NO.	DESCRIPTION
1	1557573	Uph. #11 Pad Assembly**
2	1558897	Headrest Cover
3	1562499	3/8" Adjustable Handle
4	1558903	Mounting Plate*
5	1559295	Headrest Lock Block
6	1559395	Headrest Pad Mounting Plate
7	1207199	3/4 O.D. x 3/8 I.D. x 3/4 Spacer
8	1562899	S.H.S.S., 3/8-16 x 2 1/2
9	0472999	Retaining Ring
10	1559599	R.H.M.S., 1/4-20 x 2 1/2
11	1526399	T.H.M.S., 5/16-18 x 1/2
12	1571799	Short Standoff
13	1559092	Stud Mount Assembly
14	0712999	F.H.M.S., 1/4-20 x 3/4
15	1559499	F.H.M.S., 3/8-16 x 3/4
16	0713199	R.H.M.S., 1/4-20 x 3/4
17	0728299	1/4 Lockwasher
18	1454799	B.H.C.S., 1/4-28 x 1/2

To order complete Headrest Assembly use P/N.

155720 #11 Headrest Assembly*

*Please specify paint color when ordering.

** Please specify upholstery color when ordering.

FIGURE 18
21 HEADREST ASSEMBLY

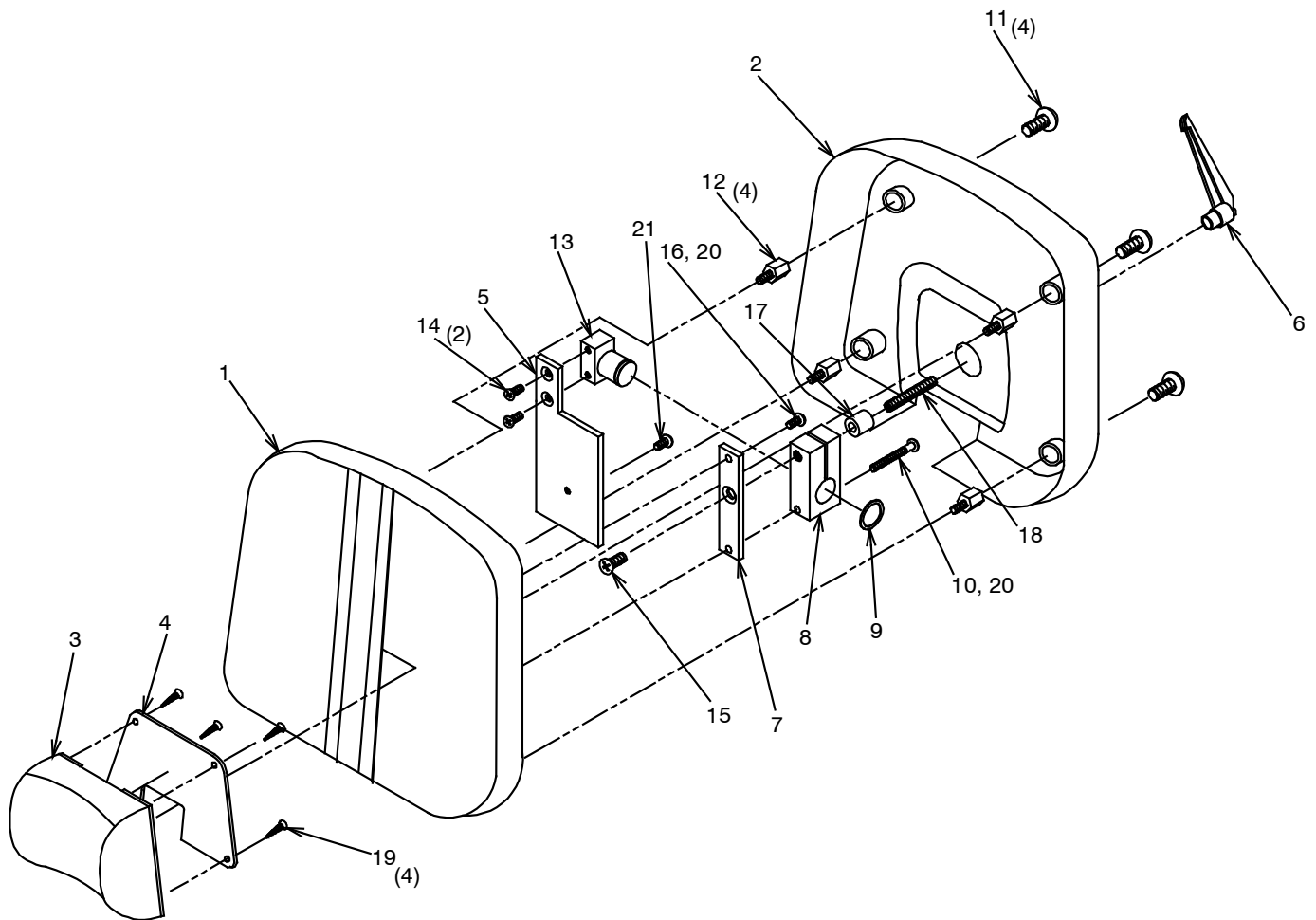

ITEM	PART NO.	DESCRIPTION
1	1846373	Uph. #21 Board Assembly**
2	1558897	Headrest Cover
3	0574173	Pillow Assembly**
4	0568003	Pillow Board Back Cover*
5	1558903	Mounting Plate*
6	1562499	3/8" Adjustable Handle
7	1559395	Headrest Pad Mounting Plate
8	1559295	Headrest Lock Block
9	0472999	Retaining Ring
10	1559599	R.H.M.S., 1/4-20 x 2 1/2
11	1526399	T.H.M.S., 5/16-18 x 1/2
12	1571799	Short Standoff
13	1559092	Stud Mount Assembly
14	0712999	F.H.M.S., 1/4-20 x 3/4
15	1559499	F.H.M.S., 3/8-16 x 3/4
16	0713199	R.H.M.S., 1/4-20 x 3/4
17	1207199	3/4 O.D. x 3/8 I.D. x 3/4 Spacer
18	1562899	S.H.S.S., 3/8-16 x 2 1/2
19	0845199	F.H.W.S., #6 x 1/2 - Phil
20	0728299	1/4 Lockwasher
21	1454799	B.H.C.S., 1/4-28 x 1/2

To order complete Headrest Assembly use P/N.

184640 #21 Headrest Assembly*

*Please specify paint color when ordering.

** Please specify upholstery color when ordering.

FIGURE 19
20 HEADREST ASSEMBLY

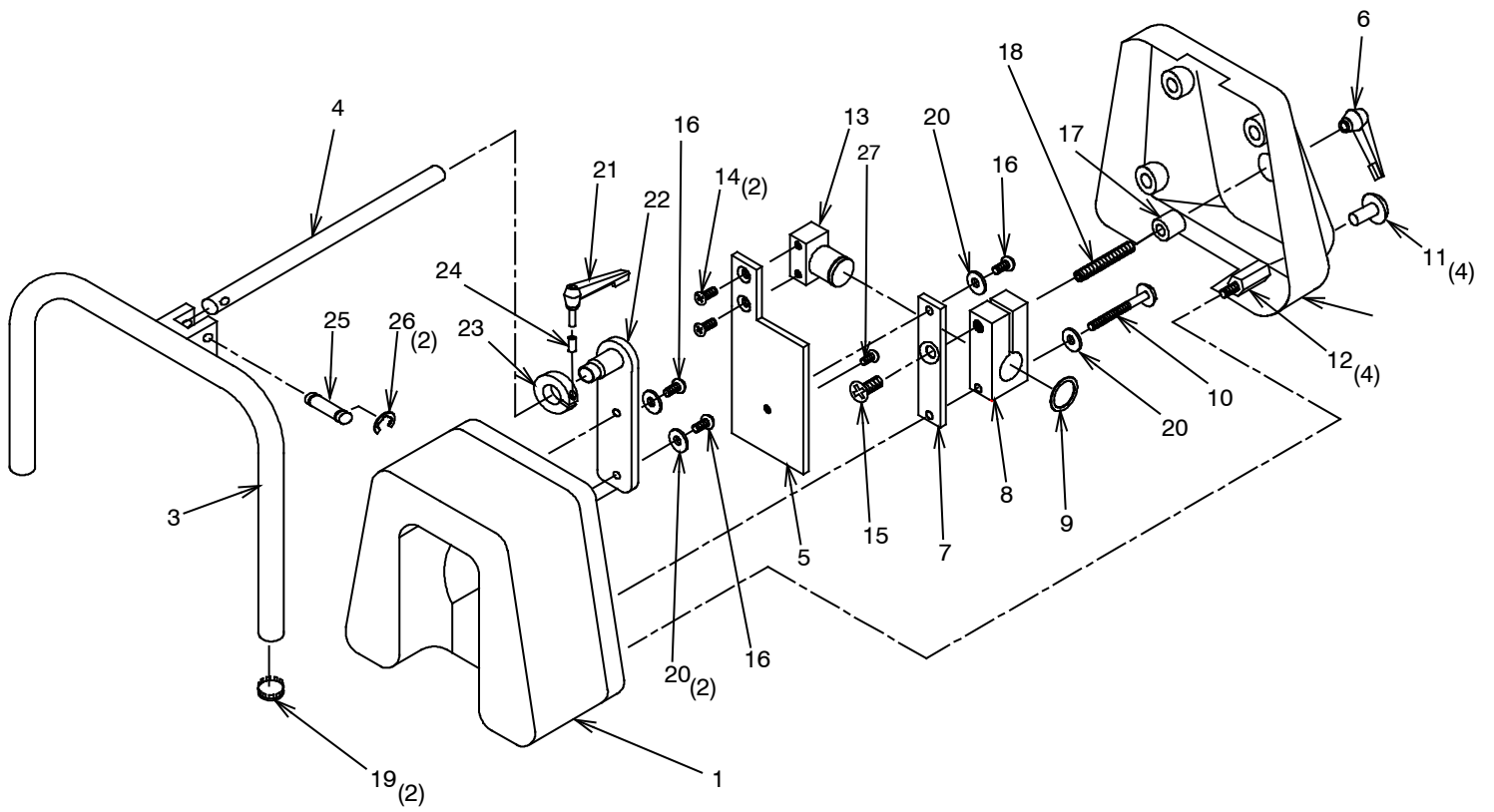

ITEM	PART NO.	DESCRIPTION	ITEM	PART NO.	DESCRIPTION
1	1600273	Uph # 20 Headrest Cushion**	15	1559499	F.H.M.S 3/8-16 x 3/4
2	1593997	Headrest Cover	16	0713199	R.H.M.S 1/4-20 x 3/4
3	1594982	Arm Support Weldment	17	1207199	3/4 O.D x 3/8 I.D x 3/4 Spacer
4	1594699	Arm Support Post	18	1562899	S.H.S.S. 3/8-16 x 2 1/2
5	1558903	Mounting Plate*	19	0948199	Plug Button
6	1562499	3/8" Adjustable Handle	20	0728299	1/4 Lockwasher
7	1559395	Headrest Pad Mounting Plate	21	1613982	Adjustable Handle
8	1559295	Headrest Lock Block	22	1594879	Support Plate Weldment
9	0472999	Retaining Ring	23	1594599	Lock Clamp
10	1559599	R.H.M.S 1/4-20 x 2 1/2	24	1613895	Sleeve Spacer
11	1523699	T.H.M.S. 5/16-18 x 1/2	25	1594499	Rotation Pin
12	1571799	Short Standoff	26	0732599	Retaining Ring
13	1559092	Stud Mount Assembly	27	1454799	B.H.M.S 1/4-28 x 1/2
14	0712999	F.H.M.S 1/4-20 x 3/4	28		

To order complete Headrest Assembly use P/N.

159500 #20 Headrest Assembly*

*Please specify paint color when ordering.

** Please specify upholstery color when ordering.

FIGURE 20
27 HEADREST ASSEMBLY

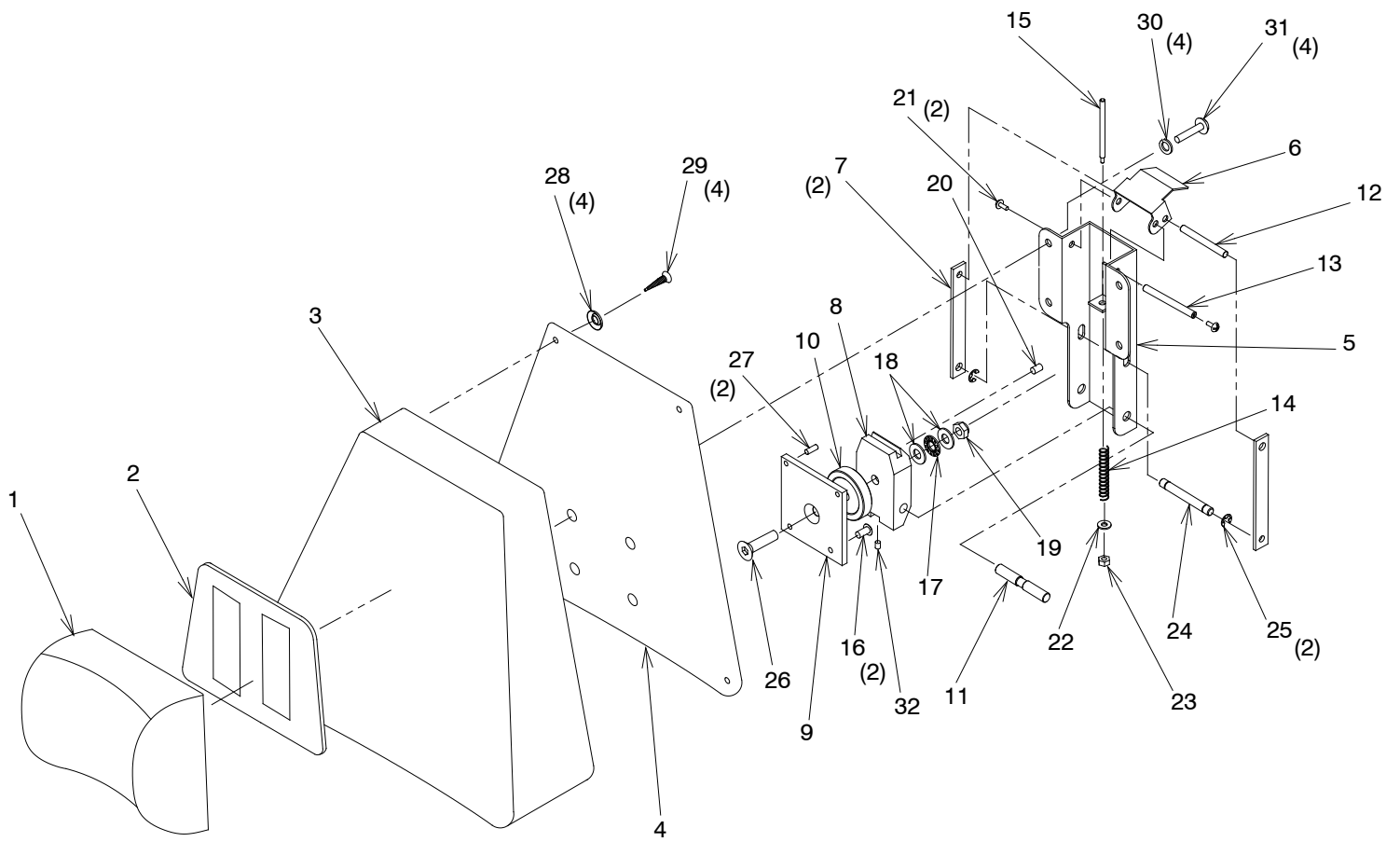

ITEM	PART NO.	DESCRIPTION
1	1920873	Uph. Pillow - Magnetic**
2	1920973	Pillow Back Cover Assembly**
3	1920773	Uph. Headrest Board**
4	1923003	Headrest Back Cover*
5	1922803	Headrest Housing*
6	1922903	Release Lever*
7	1921979	Release Link
8	1921676	Pivot Block
9	1921879	Mounting Plate
10	1921799	Nylon Spacer
11	1922499	Pivot Pin
12	1922299	Internal Pin
13	1922399	Release Lever Pin
14	1922099	Spring
15	1922199	Spring Pin
16	1454799	B.H.C.S., 1/4-28 x 1/2
17	1725599	Thrust Bearing
18	1725699	Thrust Washer
19	0304599	3/8-16 Lock Nut
20	0722899	S.S.H.S., 1/4-20 x 3/8
21	0290299	T.H.M.S., #6-32 x 3/8
22	0729899	Washer
23	0282599	#10-24 Flexlock Nut
24	1922599	Locking Pin
25	0673399	Retaining Ring
26	1806699	F.H.C.S., 3/8-16 x 1 1/2
27	0761799	3/16 x .50 Roll Pin
28	0569799	#6 Washer
29	0569699	O.H.W.S., #6 x 3/4
30	0728299	1/4 Split Lock Washer
31	0292799	R.H.M.S., 1/4-20x 1.00 - Zinc
32	0802599	S.S.H.S., #10-24 x 1/4

To order complete Headrest Assembly use P/N.

192050 #27 Headrest Assembly*

*Please specify paint color when ordering.

** Please specify upholstery color when ordering.

FIGURE 21
C6 HEADREST ASSEMBLY

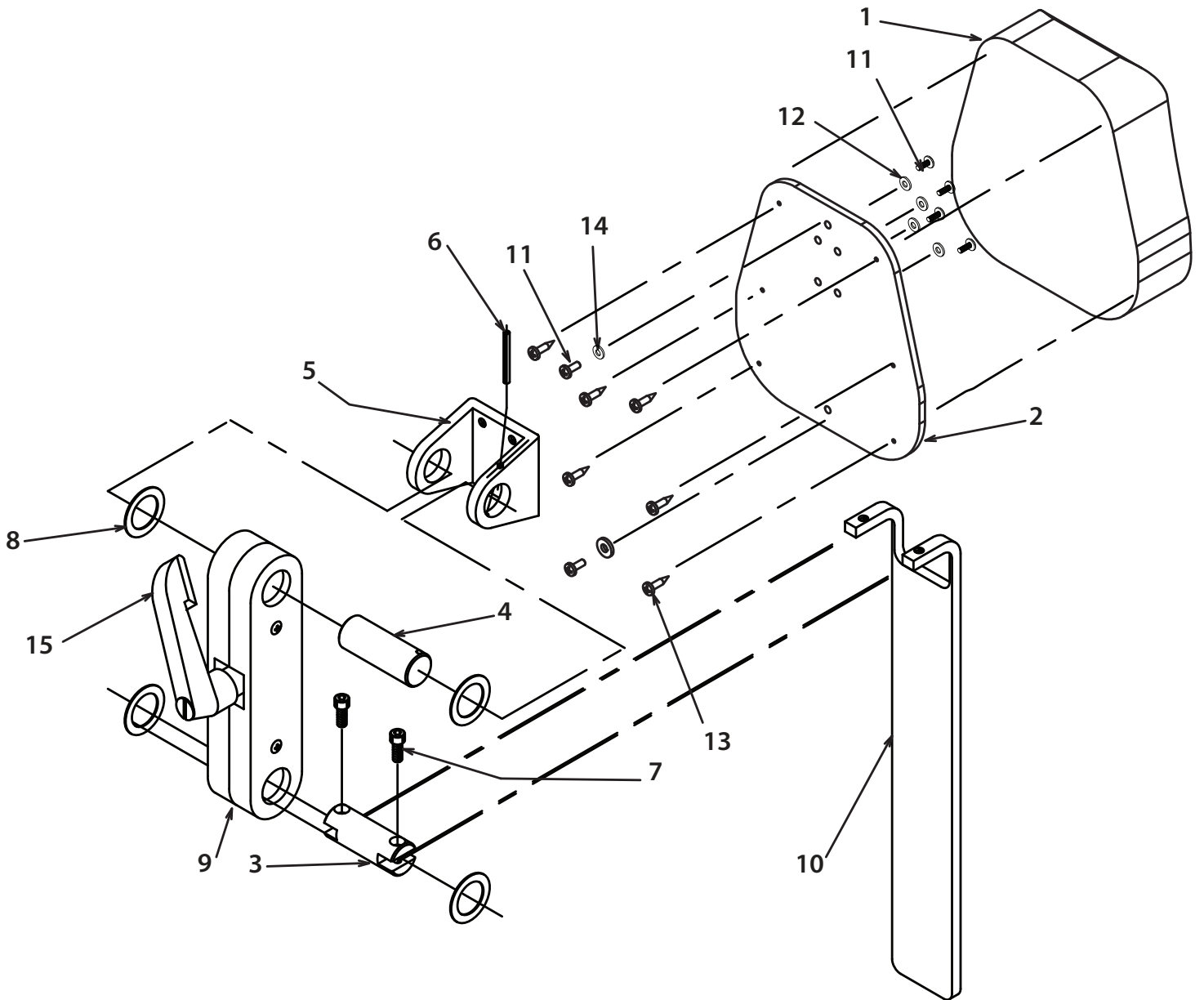

ITEM	PART NO.	DESCRIPTION
1	2262300	Uph. Pillow Artic Headrest**
2	1948600	Back Cover Assembly
3	2257799	Pin, Elevator Bar
4	2257699	Pin, Pivot
5	2262199	U-Bracket, Lock Hinge
6	2287299	Roll Pin, .13 x 1.25
7	2261999	S.H.C.S., #10-24 x .50 Long
8	0527699	Washer, 1.13 O.D x .76 I.D.
9	2336000	Sub-Assembly, Lock Mechanism
10	2262299	Elevator Bar, Short Bend
11	2262099	F.H.C.S., #10-24 x .63
12	0730199	Washer, .312 SAE
13	2115499	O.H.W.S. w/Washer, #8 x .75
14	0401699	Washer, #10
15	1562499	Handle Adj. - 3/8

To order complete Headrest Assembly use P/N.

030601 C6 Headrest Assembly*

*Please specify paint color when ordering.

** Please specify upholstery color when ordering.

FIGURE 22
30 HEADREST ASSEMBLY

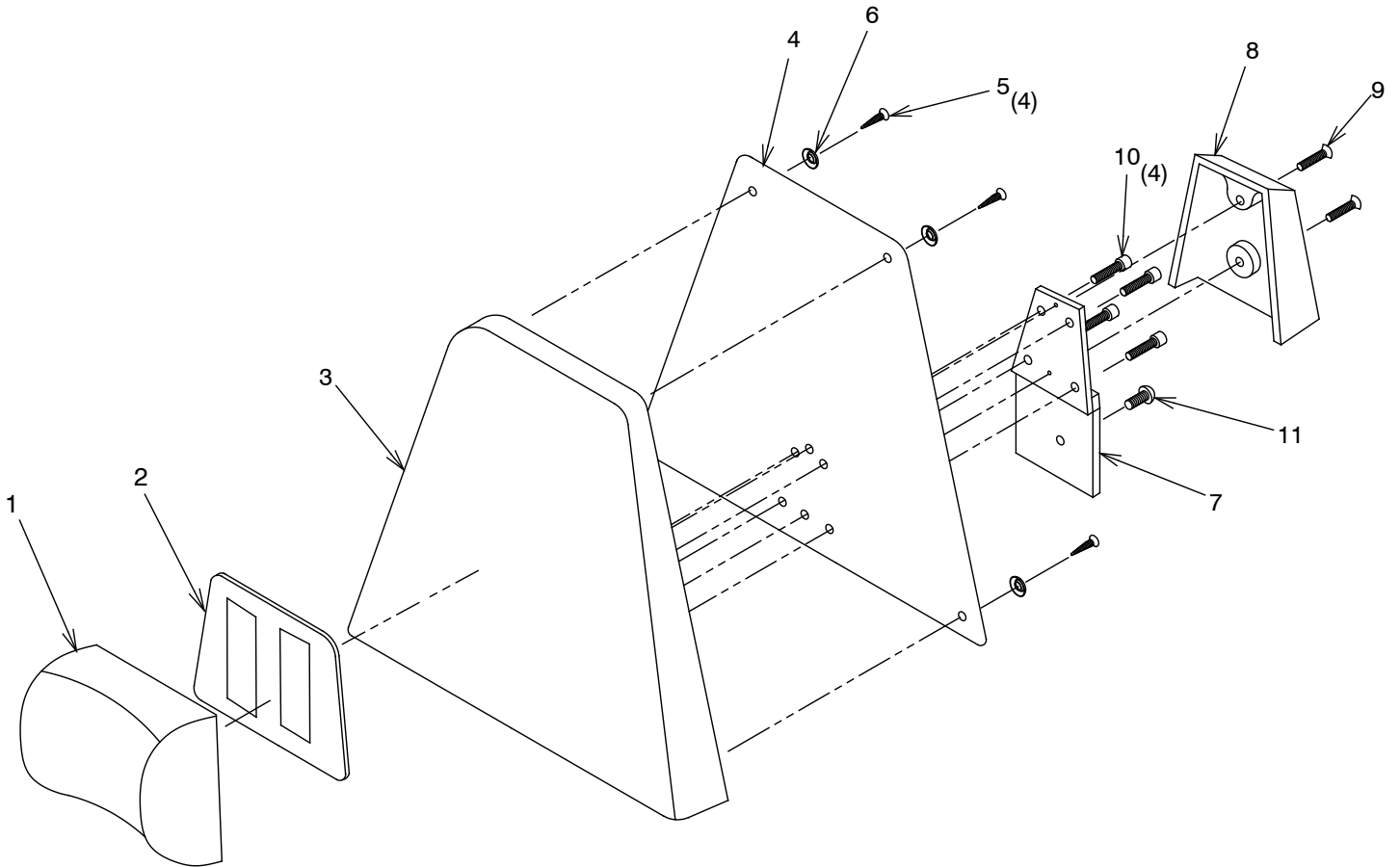

ITEM	PART NO.	DESCRIPTION
1	1920873	Uph. Pillow - Magnetic**
2	1920973	Pillow Back Cover Assembly**
3	3036573	Uph. Headrest Board**
4	0567903	Headrest Back Cover*
5	0569699	O.H.W.S. #6 x 3/4
6	0569799	#6 Finishing Washer
7	0557499	Mounting Plate Assembly
8	0123203	Bracket Cover*
9	1111399	F.H.C.S 1/4-20 x 3/4 - Socket
10	0788699	S.H.C.S. 1/4-20 x 1.00
11	1454799	B.H.C.S., 1/4-28 x 1/2

To order complete Headrest Assembly use P/N.

303640 #30 Headrest Assembly*

*Please specify paint color when ordering.

** Please specify upholstery color when ordering.

FIGURE 23
31 HEADREST ASSEMBLY

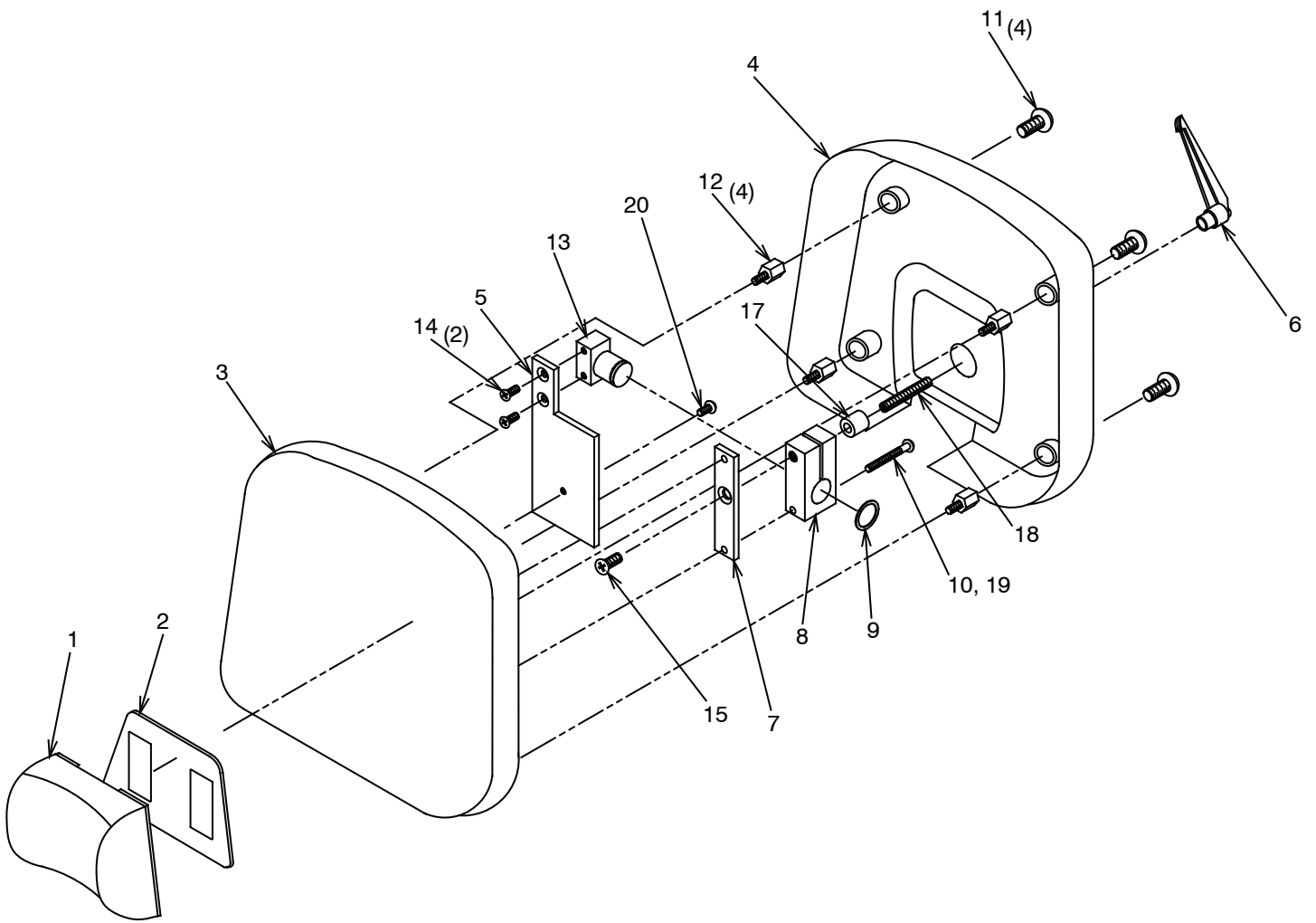

ITEM	PART NO.	DESCRIPTION
1	1920873	Uph. Pillow - Magnetic
2	1920973	Pillow Back Cover Assembly
3	3075173	Uph. Headrest Board - #31
4	1558897	Headrest Cover
5	1558903	Mounting Plate*
6	1562499	3/8" Adjustable Handle
7	1559395	Headrest Pad Mounting Plate
8	1559295	Headrest Lock Block
9	0472999	Retaining Ring
10	1559599	R.H.M.S., 1/4-20 x 2 1/2
11	1526399	T.H.M.S., 5/16-18 x 1/2
12	1571799	Short Standoff
13	1559092	Stud Mount Assembly
14	0712999	F.H.M.S., 1/4-20 x 3/4
15	1559499	F.H.M.S., 3/8-16 x 3/4
16	0713199	R.H.M.S., 1/4-20 x 3/4
17	1207199	3/4 O.D. x 3/8 I.D. x 3/4 Spacer
18	1562899	S.H.S.S., 3/8-16 x 2 1/2
19	0728299	1/4 Lockwasher
20	1454799	B.H.C.S., 1/4-28 x 1/2

To order complete Headrest Assembly use P/N.

307500 #31 Headrest Assembly*

*Please specify paint color when ordering.

** Please specify upholstery color when ordering.

**FIGURE 24
WIRING DIAGRAM**

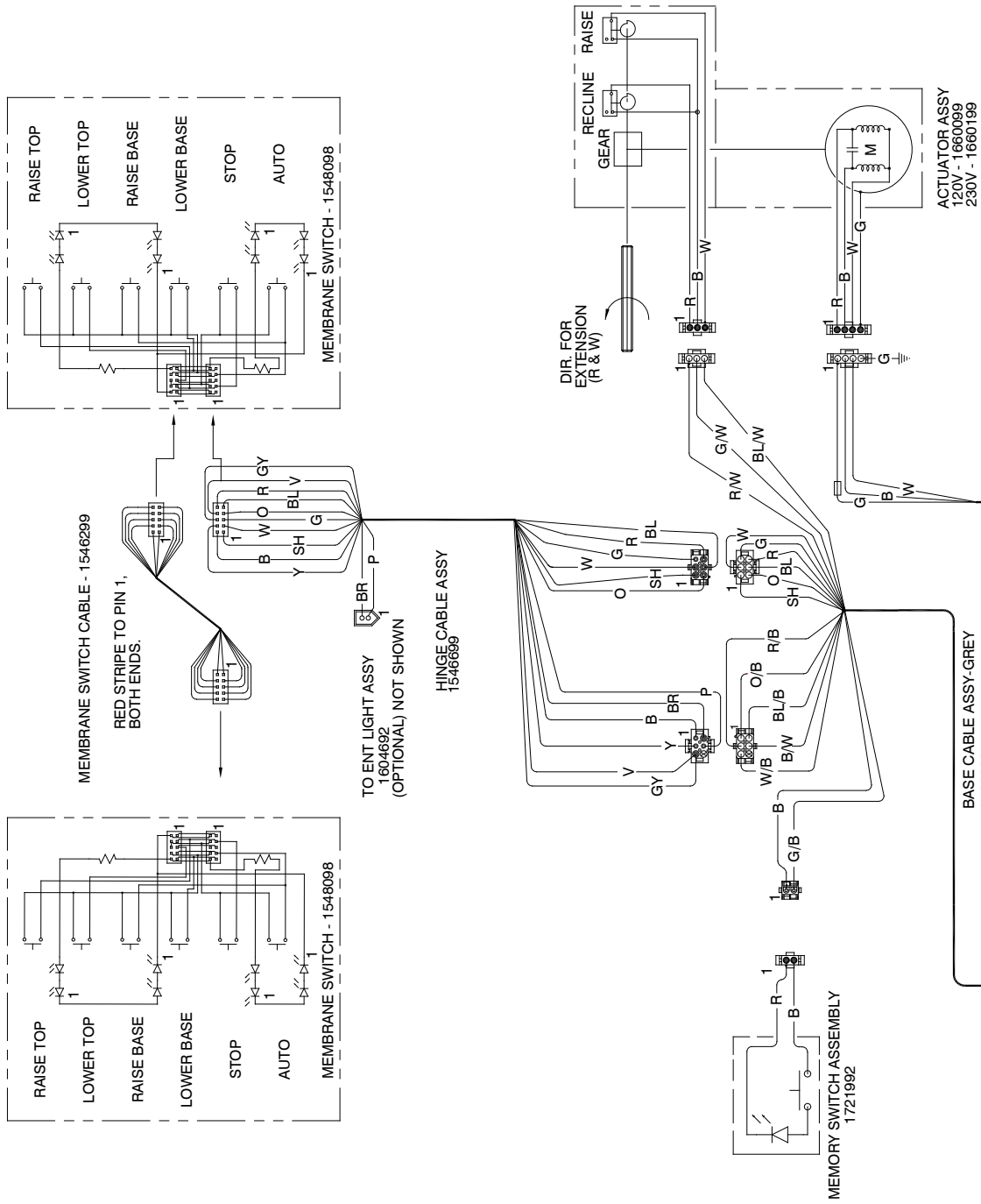

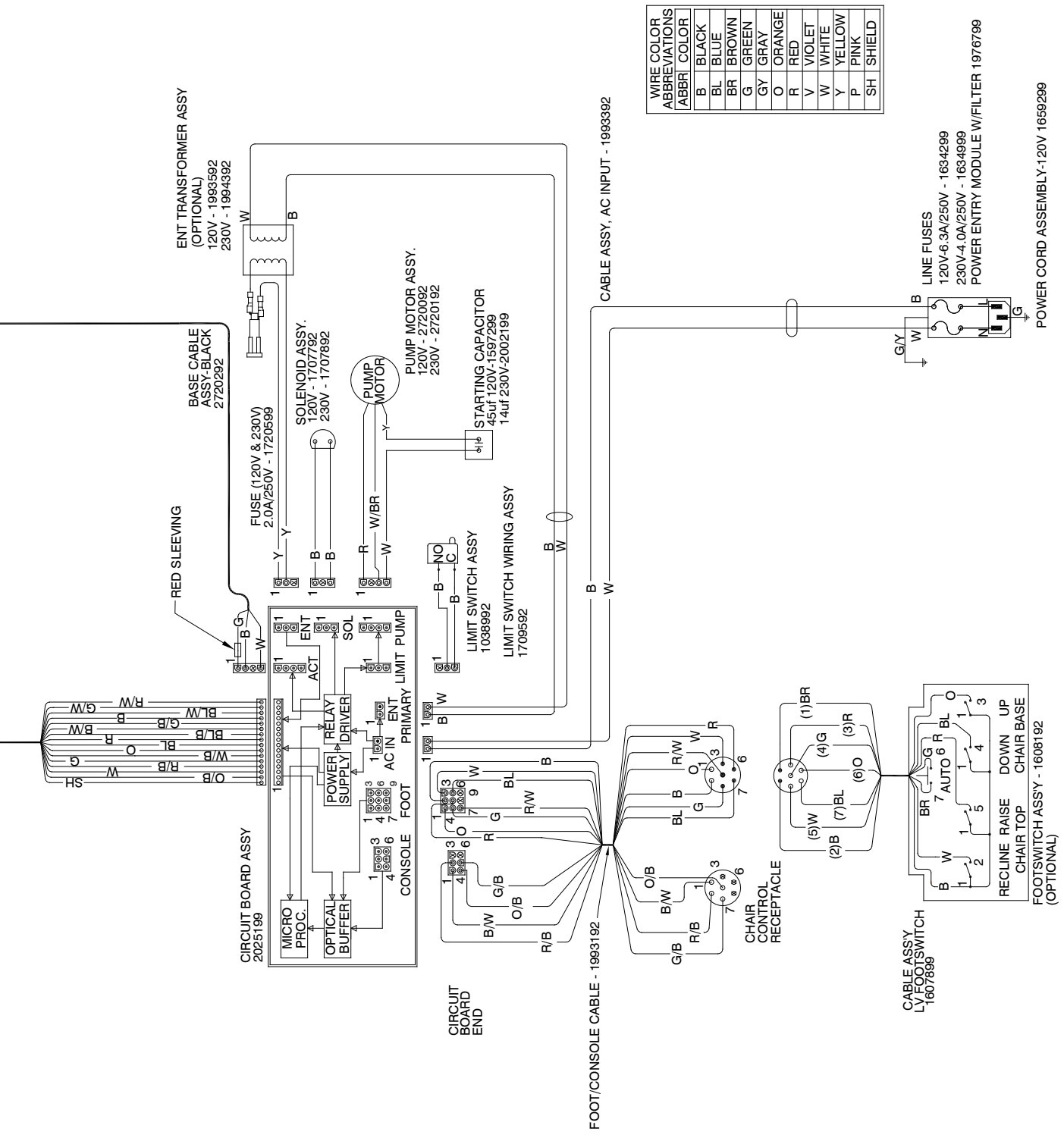

(NOTES)

LIMITED WARRANTY

The Reliance® product must be used only for the purposes and in the manner described in the literature distributed with the product. The products are warranted against defective materials and workmanship for a period of one (1) year from date of installation. Products or parts thereof will be repaired or replaced as required at Reliance® Medical Products, Inc. Such repair or replacement shall be the sole remedy under this warranty. This warranty extends only to the original purchaser from an authorized Reliance® dealer and is subject to the following conditions:

1. The warranty card must be completed and returned to Reliance® Medical Products, Inc. within two (2) weeks from the date of installation.
2. Installation and servicing of the products must be performed by trained Reliance® equipment dealer service personnel in accordance with the appropriate instructions manual for the products. Warranty will be voided if installation is performed by a non-authorized individual
3. The products have not sustained breakage or other types of damage due to accident or misuse.
4. This warranty will not apply to Reliance® products which have had the serial number removed, altered or effaced.

EXCEPT FOR THE EXPRESS WARRANTY SET FORTH ABOVE, RELIANCE® DOES NOT GRANT ANY WARRANTIES, EITHER EXPRESS OR IMPLIED, INCLUDING IMPLIED WARRANTIES OF MERCHANTABILITY OR FITNESS FOR A PARTICULAR USE.

Reliance® Medical Products neither assumes nor authorizes any person to assume for it, any other liability in connection with the sale and use of its products.

REMEDIES ARE LIMITED EXCLUSIVELY TO REPAIR OR REPLACEMENT OF PARTS. RELIANCE® MEDICAL PRODUCTS, INC. EXPRESSLY DISCLAIMS LIABILITY FOR INCIDENTAL OR CONSEQUENTIAL DAMAGE RESULTING FROM THE USE OF THE EQUIPMENT.

Claims covered by this warranty will be honored when presented within one (1) month from discovery of a defect.

EC	REP	Authorized European Community Representative
HAAG-STREIT UK		
Edinburgh Way		
Harlow, Essex, England		
CM20 2TT		
United Kingdom		



Reliance Medical Products, Inc
3535 Kings Mills Road
Mason, Ohio 45040-2303 USA
1-800-735-0357 (Customer Service)
1-800-735-0358 (Technical Service)
(513) 398-3937
[Http://www.reliance-medical.com](http://www.reliance-medical.com)

P/N 27138 REV F
© Copyright 2008
Printed in U.S.A.
Revised 04-2017-8920